



**TENDER FOR FABRICATION, SUPPLY AND INSTALLATION  
OF 40FT CONTAINER**

**TENDER NUMBER. AICHM/MI/CONT/091124**

*Executive Director*  
*AIC Health Ministries*  
*P.O. Box 40431 – 00100*  
*Nairobi, Kenya*  
**Tel: +254 20 8000474**  
**Email: [tenders@aichm.org](mailto:tenders@aichm.org)**

**Issuing date: 9<sup>th</sup> December 2024**  
**Closing Date: 24<sup>th</sup> December 2024 at 5:00 PM (East African Time)**

## **Introduction**

Africa Inland Church Health Ministries (AICHM) is a department of the Africa Inland Church (AIC) responsible for health, livelihood and resilience programs within the church.

AICHM has extensive experience in working with various population groups in Kenya, particularly the pastoral population groups in the arid and semi-arid (ASAL) regions and implements humanitarian aid and development cooperation projects in the priority areas of health and livelihoods.

## TABLE OF CONTENTS

ABBREVIATIONS AND ACRONYMS .....	6
SECTION I: INVITATION FOR TENDERS (IFT) .....	7
SECTION II: INSTRUCTIONS TO TENDERERS (ITT).....	8
A.    Introduction .....	11
1.    Scope of Tender .....	11
2.    Source of Funds .....	11
3.    Eligible Tenderers.....	11
4.    One Tender per Tenderer .....	12
5.    Alternative Tenders by Tenderers.....	12
6.    Cost of Tendering.....	12
7.    Site Visit and Pre-Tender Meeting.....	12
B.    Tendering Documents .....	13
8.    Content of Tendering Documents.....	13
9.    Clarification of Tendering Documents.....	14
10.   Amendments of the Tendering Documents.....	14
C.    Preparation of Tenders .....	14
11.   Language of Tender .....	14
12.   Documents Constituting the Tender.....	14
13.   Documents Establishing Eligibility and Qualifications of the Tenderer.....	15
14.   Lots Package .....	16
15.   Form of Tender .....	16
16.   Tender Prices .....	16
17.   Tender Currencies.....	16
18.   Tender Validity Period.....	17
19.   Tender Securing Declaration -NOT REQUIRED FOR THIS TENDER.....	17
20.   Format and Signing of Tender .....	17
D.    Submission of Tenders .....	18
21.   Sealing and Marking of Tenders .....	18
22.   Deadline for Submission of Tenders.....	18
23.   Late Tenders.....	18
24.   Modification, Substitution and Withdrawal of Tenders.....	18
E.    Opening and Evaluation of Tenders.....	19
25.   Opening of Tenders.....	19
26.   Confidentiality .....	19
27.   Clarification of Tenders .....	19
28.   Mandatory Preliminary Examination of Tenders.....	20
29.   Correction of Errors .....	22
30.   Conversion to Single Currency .....	22
31.   Comparison of Tenders.....	22
32.   National Preference.....	23
33.   Determination of the winning Bidder .....	23
34.   Post-qualification of Tenderer .....	23
F.    Award of Contract.....	24
35.   Criteria of Award .....	24
36.   Clarifications.....	24
37.   Procuring Entity’s Right to Accept any Tender and to Reject any or all Tenders. 25	
38.   Procuring Entities Right to Vary Quantities at the Time of Award.....	25
39.   Notification of Award .....	25
40.   Signing of Contract.....	26
41.   Performance Security- NOT REQUIRED FOR THIS TENDER.....	26

42. Advance Payment .....	26
SECTION III: TENDER DATA SHEET .....	28
IV: GENERAL CONDITIONS OF CONTRACT Table of Clauses.....	32
A. General .....	36
1. Definitions.....	36
2. Interpretation .....	37
3. Language, Law, Fraud and Corruption .....	38
4. Confidentiality .....	39
5. Project Manager’s Decisions .....	39
6. Delegation .....	39
7. Communications .....	39
8. Subcontracting .....	39
9. Other Contractors.....	39
10. Personnel.....	39
11. Procuring Entity’s and Contractor’s Risks.....	39
12. Procuring Entity’s Risks .....	39
13. Contractor’s Risks.....	40
14. Site Investigation Reports .....	40
15. Queries about the Contract Data Sheet .....	40
16. Contractor to Construct the Works .....	40
17. Commencement and Completion.....	40
18. Approval by the Project Manager .....	40
19. Protection of the Environment .....	40
20. Labour Laws .....	40
21. Health and Safety .....	40
22. Discoveries.....	41
23. Possession of the Site.....	41
24. Access to the Site .....	41
25. Instructions, Inspections and Audits .....	41
B. Time Control .....	41
26. Programme.....	41
27. Extension of the Intended Completion Date .....	41
28. Acceleration .....	42
29. Delays Ordered by the Project Manager .....	42
30. Management Meetings.....	42
31. Early Warning.....	42
C. Quality Control.....	42
32. Identifying Defects.....	42
33. Tests .....	42
34. Correction of Defects .....	42
35. Uncorrected Defects.....	42
D. Cost Control .....	43
36. Bill of Quantities.....	43
37. Cash Flow Forecasts .....	43
38. Payment Certificates .....	43
39. Payments .....	43
40. Compensation Events.....	43
41. Taxes .....	44
42. Currencies .....	44
43. Price Adjustment.....	44
44. Liquidated Damages .....	44
45. Performance Securities -Will Not Be required for this Tender.....	44
46. Cost of Repairs.....	45

E.	Finishing the Contract .....	45
47.	Completion Certificate .....	45
48.	Taking Over .....	45
49.	Final Account .....	45
50.	Operating and Maintenance Manuals.....	45
51.	Termination .....	45
52.	Payment upon Termination .....	46
53.	Property.....	46
54.	Release from Performance .....	46
55.	Suspension of Financing .....	46
SECTION V: CONTRACT DATA SHEET (CDS) .....		47
SECTION VI: TECHNICAL SPECIFICATIONS .....		51
SECTION VII: DRAWINGS .....		57
<i>SECTION VIII: BILL OF QUANTITIES.....</i>		<i>58</i>
SECTION IX: TENDER FORMS .....		74
A.	Form of Tender.....	74
B.	Tender-Securing Declaration .....	76
C.	Confidential Business Questionnaire .....	77

## **ABBREVIATIONS AND ACRONYMS**

<b>CDS</b>	Contract Data Sheet
<b>GCC</b>	General Conditions of Contract
<b>IFT</b>	Invitation for Tender
<b>ITT</b>	Instruction to Tenderers
<b>PE</b>	Procuring Entity
<b>PM</b>	Project Manager
<b>STD</b>	Standard Tender Documents
<b>SOR</b>	Statement of Requirements
<b>SP</b>	Service Provider
<b>TDS</b>	Tender Data Sheet
<b>VAT</b>	Value Added Tax

## SECTION I: INVITATION FOR TENDERS (IFT)

1. AICHM invites tenders for fabrication, supply and installation of 40ft container as detailed under the tender requirements in the tender document.
2. The supplier is required under the contract to transport and install the container to the following site.

No.	Site Names	Location
1.	AIC Lopur Dispensary	Approximately 26 km from Kakuma town, Turkana County

3. Tender documents may be viewed and downloaded for free electronically from the website <https://aichm.org/tender.php>
4. The Tenderer shall chronologically serialize all pages of the tender documents submitted in the sequence of 1,2,3.... n (n being the last numerical page of the tender document)
5. Duly filled completed tender documents/quotation will shall be sent to our tender email: [tenders@aichm.org](mailto:tenders@aichm.org) with the email subject **AICHM/MI/CONT/091224**. Tender documents to reach us not later than 5:00 PM on 24<sup>th</sup> December 2024. No hard copy documents will be accepted. Opening and evaluation of bid documents will be done immediately thereafter in the presence of Tender committee members.
6. AICHM reserves the right to accept or reject any or all bids and is not obligated to give reasons
7. Any bidder who will not be contacted should consider themselves unsuccessful.
8. Late tenders will be rejected

---

**AICHM Procurement Unit**

## SECTION II: INSTRUCTIONS TO TENDERERS (ITT)

### Table of Clauses

ABBREVIATIONS AND ACRONYMS .....	6
SECTION I: INVITATION FOR TENDERS (IFT) .....	7
SECTION II: INSTRUCTIONS TO TENDERERS (ITT).....	8
A.    Introduction .....	11
1.    Scope of Tender .....	11
2.    Source of Funds .....	11
3.    Eligible Tenderers .....	11
4.    One Tender per Tenderer .....	12
5.    Alternative Tenders by Tenderers .....	12
6.    Cost of Tendering.....	12
7.    Site Visit and Pre-Tender Meeting.....	12
B.    Tendering Documents .....	13
8.    Content of Tendering Documents .....	13
9.    Clarification of Tendering Documents.....	14
10.   Amendments of the Tendering Documents.....	14
C.    Preparation of Tenders .....	14
11.   Language of Tender .....	14
12.   Documents Constituting the Tender.....	14
13.   Documents Establishing Eligibility and Qualifications of the Tenderer.....	15
14.   Lots Package .....	16
15.   Form of Tender .....	16
16.   Tender Prices .....	16
17.   Tender Currencies .....	16
18.   Tender Validity Period.....	17
19.   Tender Securing Declaration -NOT REQUIRED FOR THIS TENDER.....	17
20.   Format and Signing of Tender .....	17
D.    Submission of Tenders .....	18
21.   Sealing and Marking of Tenders .....	18
22.   Deadline for Submission of Tenders.....	18
23.   Late Tenders.....	18
24.   Modification, Substitution and Withdrawal of Tenders.....	18
E.    Opening and Evaluation of Tenders.....	19
25.   Opening of Tenders.....	19
26.   Confidentiality .....	19
27.   Clarification of Tenders .....	19
28.   Mandatory Preliminary Examination of Tenders.....	20
29.   Correction of Errors .....	22
30.   Conversion to Single Currency .....	22
31.   Comparison of Tenders.....	22
32.   National Preference.....	23
33.   Determination of the winning Bidder .....	23
34.   Post-qualification of Tenderer .....	23
F.    Award of Contract.....	24
35.   Criteria of Award .....	24
36.   Clarifications.....	24
37.   Procuring Entity's Right to Accept any Tender and to Reject any or all Tenders.	25
38.   Procuring Entities Right to Vary Quantities at the Time of Award .....	25
39.   Notification of Award .....	25
40.   Signing of Contract.....	26



41. Performance Security- NOT REQUIRED FOR THIS TENDER .....	26
42. Advance Payment .....	26
<b>SECTION III: TENDER DATA SHEET .....</b>	<b>28</b>
<b>IV: GENERAL CONDITIONS OF CONTRACT Table of Clauses.....</b>	<b>32</b>
<b>A. General .....</b>	<b>36</b>
1. Definitions.....	36
2. Interpretation .....	37
3. Language, Law, Fraud and Corruption .....	38
4. Confidentiality .....	39
5. Project Manager’s Decisions .....	39
6. Delegation .....	39
7. Communications .....	39
8. Subcontracting .....	39
9. Other Contractors.....	39
10. Personnel.....	39
11. Procuring Entity’s and Contractor’s Risks.....	39
12. Procuring Entity’s Risks .....	39
13. Contractor’s Risks.....	40
14. Site Investigation Reports .....	40
15. Queries about the Contract Data Sheet .....	40
16. Contractor to Construct the Works .....	40
17. Commencement and Completion.....	40
18. Approval by the Project Manager .....	40
19. Protection of the Environment .....	40
20. Labour Laws .....	40
21. Health and Safety .....	40
22. Discoveries.....	41
23. Possession of the Site.....	41
24. Access to the Site .....	41
25. Instructions, Inspections and Audits .....	41
<b>B. Time Control .....</b>	<b>41</b>
26. Programme.....	41
27. Extension of the Intended Completion Date .....	41
28. Acceleration .....	42
29. Delays Ordered by the Project Manager .....	42
30. Management Meetings .....	42
31. Early Warning.....	42
<b>C. Quality Control.....</b>	<b>42</b>
32. Identifying Defects.....	42
33. Tests .....	42
34. Correction of Defects .....	42
35. Uncorrected Defects.....	42
<b>D. Cost Control .....</b>	<b>43</b>
36. Bill of Quantities.....	43
37. Cash Flow Forecasts .....	43
38. Payment Certificates .....	43
39. Payments .....	43
40. Compensation Events.....	43
41. Taxes .....	44
42. Currencies .....	44
43. Price Adjustment.....	44
44. Liquidated Damages .....	44
45. Performance Securities -Will Not Be required for this Tender.....	44

46.	Cost of Repairs.....	45
E.	Finishing the Contract .....	45
47.	Completion Certificate.....	45
48.	Taking Over .....	45
49.	Final Account.....	45
50.	Operating and Maintenance Manuals.....	45
51.	Termination.....	45
52.	Payment upon Termination.....	46
53.	Property.....	46
54.	Release from Performance .....	46
55.	Suspension of Financing .....	46
SECTION V: CONTRACT DATA SHEET (CDS) .....		47
SECTION VI: TECHNICAL SPECIFICATIONS .....		51
SECTION VII: DRAWINGS .....		57
<i>SECTION VIII: BILL OF QUANTITIES.....</i>		<i>58</i>
SECTION IX: TENDER FORMS .....		74
A.	Form of Tender.....	74
B.	Tender-Securing Declaration .....	76
C.	Confidential Business Questionnaire .....	77

## A. Introduction

<b>1. Scope of Tender</b>	<b>1.1</b>	The Procuring Entity indicated in the <b>Tender Data Sheet (TDS)</b> invites Tenders for the fabrication, supply and fabrication works as specified in the <b>Tender Data Sheet</b> and Sections VI (Technical Specifications) and VII (Drawings).
	<b>1.2</b>	The successful Tenderer will be expected to complete the works by the required completion date specified in the <b>Tender Data Sheet</b> .
	<b>1.3</b>	The objectives of the works are listed in the <b>Tender Data Sheet</b> . These are mandatory requirements. Any subsequent detail is offered to support these objectives and must not be used to dilute their importance.
<b>2. Source of Funds</b>	<b>2.1</b>	<b>Africa Inland Church Health Ministries (AICHM) through funding from Malteser International</b>
	<b>2.2</b>	Payments will be made directly by the Procuring Entity and will be subject in all respects to the terms and conditions of the resulting contract placed by the Procuring Entity.
<b>3. Eligible Tenderers</b>	<b>3.1</b>	A Tenderer may be private or public company or any combination of them with a formal intent to enter into an agreement or under an existing agreement in the form of a joint venture, consortium, or association. In the case of a joint venture, consortium, or association, unless otherwise specified in the <b>Tender Data Sheet</b> , all parties shall be jointly and severally liable.
	<b>3.2</b>	The Invitation for Tenders is open to all suppliers as defined in the AICHM policy.
	<b>3.3</b>	National Tenderers shall satisfy all relevant licensing and/or registration with the appropriate statutory bodies in Kenya, such as the National Construction Authority relevant categories as per the tender data sheet.
	<b>3.4</b>	<p>A Tenderer shall not have a conflict of interest. All Tenderers found to have a conflict of interest shall be disqualified. A Tenderer may be considered to have a conflict of interest with one or more parties in this Tendering process, if they:</p> <ul style="list-style-type: none"> <li>Are associated or have been associated in the past directly or indirectly with employees or agents of the Procuring Entity or a member of a board or committee of the Procuring Entity;</li> <li>Receive or have received any direct or indirect subsidy from any of them; or</li> <li>Have a relationship with each other, directly or through common third parties, that puts them in a position to have access to information about or influence on the Tender of another Tenderer, or influence the decisions of the Procuring Entity regarding this Tendering process; or</li> </ul>

		Submit more than one Tender in this Tendering process, However, this does not limit the participation of subcontractors in more than one Tender, or as Tenderer and subcontractor simultaneously.
	3.5	Tenderers shall not be under a declaration of ineligibility for corrupt and fraudulent practices.
<b>4. One Tender per Tenderer</b>	4.1	A firm shall submit only one Tender, in the same Tendering process, either individually as a Tenderer or as a partner in a joint venture pursuant to ITT Clause 5.
	4.2	No firm can be a subcontractor while submitting a Tender individually or as a partner of a joint venture in the same Tendering process.
	4.3	A firm, if acting in the capacity of subcontractor in any Tender, may participate in more than one Tender but only in that capacity.
	4.4	A Tenderer who submits or participates in more than one Tender (other than as a subcontractor or in cases of alternatives that have been permitted or requested) will cause all the Tenders in which the Tenderer has participated to be disqualified.
<b>5. Alternative Tenders by Tenderers</b>	5.1	Tenderers shall submit offers that comply with the requirements of the Tendering documents, including the basic Tenderer's technical design as indicated in the specifications and Drawings and Bill of Quantities. Alternatives will not be considered, unless specifically allowed for in the <b>Tender Data Sheet</b> . If so allowed, sub-Clause 5.2 and 5.3 shall govern.
	5.2	When alternative times for completion are explicitly invited, a statement to that effect will be included in the <b>Tender Data Sheet</b> as will the method of evaluating different times for completion.
	5.3	If so, allowed in the <b>Tender Data Sheet</b> , Tenderers wishing to offer technical alternatives to the requirements of the Tendering documents must also submit a Tender that complies with the requirements of the Tendering documents, including the basic technical design as indicated in the specifications. In addition to submitting the basic Tender, the Tenderer shall provide all information necessary for a complete evaluation of the alternative by the Procuring Entity, including technical specifications, breakdown of prices, and other relevant details. Only the technical alternatives, if any, of the lowest evaluated Tenderer conforming to the basic technical requirements shall be considered by the Procuring Entity.
<b>6. Cost of Tendering</b>	6.1	The Tenderer shall bear all costs associated with the preparation and submission of its Tender, and the Procuring Entity shall in no case be responsible or liable for those costs, regardless of the conduct or outcome of the Tendering process.
<b>7. Site Visit and Pre-Tender Meeting</b>	7.1	The Tenderer, at the Tenderer's own responsibility and risk, is encouraged to visit and examine the Site of the Works and its surroundings and obtain all information that may be necessary for preparing the tender and entering into a contract for construction of the Works. The costs of visiting the Site shall be at the Tenderer's own expense. There will be no variation cost in the execution of the tender. The Procuring Entity in no way guarantees

		completeness nor accuracy of the soil, materials, subsurface and hydrological information made available to the Contractor at the time of tendering or at any other time during the period of the Contract, and the Contractor shall be responsible for ascertaining for himself all information as aforesaid for the execution of Works and his tender shall be deemed to have been priced accordingly
	<b>7.2</b>	Any clarification regarding the site can be sought through the following email address <a href="mailto:inquiry@aichm.org">inquiry@aichm.org</a> cc <a href="mailto:Sammy.ikeny@aichm.org">Sammy.ikeny@aichm.org</a>
	<b>7.3</b>	The Tenderer is requested as far as possible, to submit any questions by electronic means to <a href="mailto:inquiry@aichm.org">inquiry@aichm.org</a> to reach the procuring Entity on or before 5.00PM 17 <sup>th</sup> December 2024.

### B. Tendering Documents

<b>8. Content of Tendering Documents</b>	<b>8.1</b>	The works required, Tendering procedures, and contract terms are prescribed in the Tendering Documents. In addition to the Section I Invitation for Tenders, Tendering documents which should be read in conjunction with any addenda issued in accordance with ITT sub-Clause 10.2 include:
		Section II      Instructions to Tenderers Section III     Tender Data Sheet Section IV     General Conditions of Contract Section V      Contract Data Sheet Section VI     Specifications Section VII    Drawings Section VIII   Bill of Quantities Section IX     Forms of Tender <ul style="list-style-type: none"> <li>• Form of Tender</li> <li>• Appendix to Tender</li> <li>• Confidential Business Questionnaire</li> <li>• Integrity Declaration</li> <li>• Letter of Acceptance</li> <li>• Form of Contract Agreement</li> </ul> Section X      Forms of Security <ul style="list-style-type: none"> <li>• Tender Securing Declaration</li> <li>• Performance Bank or Insurance Guarantee</li> </ul>
	<b>8.2</b>	The number of copies to be completed and returned with the Tender is specified in the <b>Tender Data Sheet</b> .
	<b>8.3</b>	The Invitation for Tenders (Section I) issued by the Procuring Entity is not part of the Tendering Documents and is included for reference purposes only. In case of discrepancies between the Invitation for Tenders and the Tendering Documents listed in sub-Clause 8.1 above, the said Tendering Documents will take precedence.
	<b>8.4</b>	The Procuring Entity is not responsible for the completeness of the Tendering Documents and their addenda, if they were not obtained directly from AICHM website <a href="http://www.aichm.org">www.aichm.org</a> .

	<b>8.5</b>	The Tenderer is expected to examine all instructions, forms, terms and specifications in the Tendering documents. Failure to furnish all information required by the Tendering Documents or to submit a Tender substantially responsive to the Tendering documents in every respect will be at the Tenderer's risk and may result in the rejection of its Tender.
<b>9. Clarification of Tendering Documents</b>	<b>9.1</b>	A prospective Tenderer requiring any clarification of the Tendering documents may notify the Procuring Entity in, e-mail at the Procuring Entity's address indicated in the <b>Tender Data Sheet</b> .
	<b>9.2</b>	The Procuring Entity will within the period stated in the <b>Tender Data Sheet</b> respond in writing to any request for clarification provided that such request is received no later than the period indicated in the <b>Tender Data Sheet</b> prior to the deadline for the submission of Tenders prescribed in sub-Clause 22.1.
	<b>9.3</b>	Copies of the procuring entity's response will be forwarded to all Purchasers of the Tendering documents, including a description of the inquiry, but without identifying its source.
	<b>9.4</b>	Should the Procuring Entity deem it necessary to amend the Tendering documents as a result of a clarification, it shall do so following the procedure under ITT Clause 10.
<b>10. Amendments of the Tendering Documents</b>	<b>10.1</b>	Before the deadline for submission of Tenders, the Procuring Entity may, for any reason, whether at its own initiative or in response to a clarification requested by a prospective Tenderer, modify the Tendering documents by issuing addenda.
	<b>10.2</b>	Any addendum issued shall be part of the Tender documents pursuant to sub-Clause 8.1 and shall be communicated in writing, by e-mail to all who have obtained the Tendering documents directly from the Procuring Entity.
	<b>10.3</b>	In order to allow prospective Tenderers reasonable time in which to take an addendum into account in preparing their Tenders, the Procuring Entity at its discretion shall extend, as necessary, the deadline for submission of Tenders, in accordance with sub-Clause 22.2

### **C. Preparation of Tenders**

<b>11. Language of Tender</b>	<b>11.1</b>	The Tender, and all correspondence and documents related to the Tender exchanged by the Tenderer and the Procuring Entity shall be written in the Tender language stipulated in the <b>Tender Data Sheet</b> . Supporting documents and printed literature furnished by the Tenderer may be in another language provided they are accompanied by an accurate translation of the relevant passages in the above stated language, in which case, for purposes of interpretation of the Tender, the translation shall prevail.
<b>12. Documents Constituting the Tender</b>	<b>12.1</b>	The Tender submitted by the Tenderer shall consist of the following components:  a) The Forms of Tender

		<p>b) Information requested by Instructions to Tenderers ITT sub-Clause 13.2; 13.3 and 13.4;</p> <p>c) Tender Securing Declaration in accordance with Instructions to Tenderers ITT Clause 19;</p> <p>d) Priced Bill of Quantities;</p> <p>e) Qualification Information Form and Documents;</p> <p>f) Written confirmation authorizing the signatory of the Tender to commit the Tenderer in accordance with Instructions to Tenderers ITT sub Clause 19.2; and</p> <p>g) And any information or other materials required to be completed and submitted by Tenderers, as specified in the <b>Tender Data Sheet</b>.</p>
<b>13. Documents Establishing Eligibility and Qualifications of the Tenderer</b>	<b>13.1</b>	Pursuant to ITT Clause 13, the Tenderer shall furnish, as part of its Tender, documents establishing the Tenderer's eligibility to Tender and its qualifications to perform the contract if its Tender is accepted.
	<b>13.2</b>	In the event that pre-qualification of potential Tenderers has been undertaken, only Tenders from pre-qualified Tenderers will be considered for award of contract. These qualified Tenderers should submit their Tenders with any information updating the original pre-qualification applications or, alternatively, confirm in their Tenders that the originally submitted pre-qualification information remains essentially correct as of the date of Tender submission. The update or confirmation should be provided in Section IX.
	<b>13.3</b>	If the Procuring Entity has not undertaken pre-qualification of potential Tenderers, to qualify for award of the contract, Tenderers shall meet the minimum qualifying criteria specified in the <b>Tender Data Sheet</b> :
	<b>13.4</b>	<p>Tenders submitted by a joint venture of two or more firms as partners shall comply with the following requirements, unless otherwise stated in the <b>Tender Data Sheet</b>:</p> <p>a) The Tender shall include all the information listed in the <b>Tender Data Sheet</b> pursuant to sub-Clause 13.3 above for each joint venture partner;</p> <p>b) The Tender shall be signed so as to be legally binding on all partners;</p> <p>c) One of the partners will be nominated as being in charge, and this authorization shall be evidenced by submitting a power of attorney signed by legally authorized signatories of all the partners;</p> <p>d) The partner in charge shall be authorized to incur liabilities and receive instructions for and on behalf of any and all partners of a joint venture and the entire execution of the Contract, including payment, shall be done exclusively with the partner in charge;</p>

		<p>e) All partners of the joint venture shall be liable jointly and severally for the execution of the contract in accordance with the contract terms and a statement to this effect shall be included in the authorization mentioned under (c) above as well as in the Tender and in the Agreement (in case of a successful Tender); and</p> <p>f) A copy of the joint venture agreement entered into by all partner shall be submitted with the Tender. Alternatively, a Letter of Intent to execute a joint venture agreement in the event of a successful Tender shall be signed by all partners and submitted with the Tender, together with a copy of the proposed Agreement.</p> <p>g) Tender Securing Declaration as stated in accordance with ITT Clause 19, and in case of a successful Tender, the Agreement, shall be signed so as to be legally binding on all partners.</p>
<b>14. Lots Package</b>	<b>14.1</b>	<p>When Tendering for more than one contract under the lot's arrangements, the Tenderer must provide evidence that it meets or exceeds the sum of all the individual requirements for the lots being tendered in regard to:</p> <p>a) Average annual turnover;  b) Particular experience including key production rates;  c) Financial means, etc;  d) Personnel capabilities; and  e) Equipment capabilities.</p>
	<b>14.2</b>	<p>In case the Tenderer fail to fully meet any of these criteria, it may be qualified only for those lots for which the Tenderer meets the above requirement.</p>
<b>15. Form of Tender</b>	<b>15.1</b>	<p>The Tenderer shall fill the Form of Tender furnished in the Tendering Documents. The Form of Tender must be completed without any alterations to its format and no substitute shall be accepted.</p>
<b>16. Tender Prices</b>	<b>16.1</b>	<p>The Contract shall be for the whole Works, as described in sub-Clause 1.1, based on the priced Bill of Quantities submitted by the Tenderer.</p>
	<b>16.2</b>	<p>The Tenderer shall fill in rates and prices for all items of the Works described in the Bill of Quantities. Items for which no rate or price is entered by the Tenderer will not be paid for by the Procuring Entity when executed and shall be deemed covered by the other rates and prices in the Bill of quantities.</p>
	<b>16.3</b>	<p>All duties, taxes and other levies payable by the Contractor under the Contract, or for any other cause, as of the date 15 days prior to the deadline for submission of Tenders, shall be included in the rates, prices and total Tender price submitted by the Tenderer.</p>
	<b>16.4</b>	<p>The rates and prices quoted by the Tenderer shall not be subject to adjustment during the performance of the Contract. The Tender prices will remain fixed. The Tenderer shall submit with the Tender all the information required under the <b>Contract Data Sheet</b>.</p>
<b>17. Tender</b>	<b>17.1</b>	<p>The unit rates and prices shall be quoted by the Tenderer in the currency as</p>



<b>Currencies</b>		specified in the <b>Tender Data Sheet</b> .
<b>18. Tender Validity Period</b>	<b>18.1</b>	Tenders shall remain valid for the period specified in the <b>Tender Data Sheet</b> after the Tender submission deadline prescribed by the Procuring Entity, pursuant to ITT Clause 22. A Tender valid for a shorter period shall be rejected by the Procuring Entity as non-responsive.
	<b>18.2</b>	In exceptional circumstances, prior to expiry of the original Tender validity period, the Procuring Entity may request that the Tenderers extend the period of validity for a specified additional period. The request and the Tenderers' responses shall be made in writing by email. A Tenderer may refuse the request without forfeiting its Tender Security or causing to be executed its Tender Securing declaration. A Tenderer agreeing to the request will not be required or permitted to otherwise modify the Tender, but will be required to extend the validity of its Tender Securing declaration for the period of the extension, and in compliance with ITT Clause 19 in all respects.
<b>19. Tender Securing Declaration</b>	<b>19.1</b>	A Tender Securing Declaration as specified in the <b>Tender Data Sheet</b> in the format provided in section X shall be provided as a mandatory requirement.
	<b>19.2</b>	The Tender Securing Declaration is required to protect the Procuring Entity against the risk of Tenderer's conduct which would warrant the security's forfeiture, pursuant to ITT sub-Clause 19.9.
	<b>19.3</b>	The Tender Securing Declaration of a joint venture must be in the name of the joint venture submitting the Tender.
	<b>19.4</b>	A Tenderer shall be suspended from being eligible for Tendering in any contract with the Procuring Entity for the period of time indicated in the Tender Securing Declaration:  a) If the Tenderer withdraws its Tender, except as provided in ITT sub-Clauses 18.2 and 29.2; or  b) In the case of a successful Tenderer, if the Tenderer fails within the specified time limit to:  (i) Sign the contract; (ii) to furnish the necessary Performance Security
<b>20. Format and Signing of Tender</b>	<b>20.1</b>	The Tenderer shall prepare one original of the documents comprising the Tender as described in ITT Clause 12 of these Instructions to Tenderers, with the Form of Tender, and submitted as specified in the <b>Tender Data Sheet</b> .
	<b>20.2</b>	The original and all copies of the Tenders shall be typed or written in indelible ink and shall be signed by a person or persons duly authorized to

		sign on behalf of the Tenderer. This authorization shall consist of a written confirmation as specified in the <b>Tender Data Sheet</b> and shall be attached to the Tender. The name and position held by each person signing the authorization must be typed or printed below the signature. All pages of the Tender, except for un-amended printed literature, shall be initialled by the person or persons signing the Tender.
	<b>20.3</b>	Any interlineations, erasures, or overwriting shall be valid only if they are initialled by the person or persons signing the Tender.
	<b>20.4</b>	The Tenderer shall furnish information as described in the Form of Tender on commissions or gratuities, if any, paid or to be paid to agents relating to this Tender and to contract execution if the Tenderer is awarded the contract

#### **D. Submission of Tenders**

<b>21. Sealing and Marking of Tenders</b>	<b>21.1</b>	The Tenderer shall submit the tender through the email address specified in the data sheet on or before 5:00 P.M 24 <sup>th</sup> December 2024.
<b>22. Deadline for Submission of Tenders</b>	<b>22.1</b>	Tenders shall be received by the Procuring Entity at the address specified under ITT sub-Clause 21.1 no later than the date and time specified in the <b>Tender Data Sheet</b> .
	<b>22.2</b>	The Procuring Entity may, in exceptional circumstances and at its discretion, extend the deadline for the submission of Tenders by amending the Tendering documents in accordance with ITT Clause 9, in which case all rights and obligations of the Procuring Entity and Tenderers previously subject to the deadline will thereafter be subject to the new deadline.
	<b>22.3</b>	The extension of the deadline for submission of Tenders shall not be made later than the period specified in the <b>Tender Data Sheet</b> before the expiry of the original deadline.
<b>23. Late Tenders</b>	<b>23.1</b>	The Procuring Entity shall not consider for evaluation any Tender that arrives after the deadline for submission of Tenders, in accordance with ITT Clause 22.
	<b>23.2</b>	Any Tender received by the Procuring Entity after the deadline for submission of Tenders shall be declared late, rejected and returned unopened to the Tenderer
<b>24. Modification, Substitution and Withdrawal of Tenders</b>	<b>24.1</b>	A Tenderer may modify or substitute or withdraw its Tender after it has been submitted, provided that written notice of the modification, including substitution or withdrawal of the Tender, is received by the Procuring Entity prior to the deadline prescribed for submission of Tenders prescribed under ITT sub-Clause 22.1.
	<b>24.2</b>	The Tenderer's modification or substitution or withdrawal notice shall be prepared, and sent in accordance with the provisions of ITT Clauses 20 and 21 with the Email subject addressed " <b>MODIFICATION</b> " or <b>SUBSTITUTION</b> or " <b>WITHDRAWAL</b> " as appropriate. The notice

		may also be sent by electronic mail and facsimile, but followed by a signed confirmation copy, postmarked no later than the deadline for submission of Tenders.
	<b>24.3</b>	No Tender may be withdrawn, replaced or modified in the interval between the deadline for submission of Tenders and the expiration of the period of Tender validity specified by the Tenderer on the Tender Form. Withdrawal of a Tender during this interval shall result in the Tenderer's forfeiture of its Tender Security or execution of Tender Securing Declaration, pursuant to the ITT sub-Clause 19.9.
	<b>24.4</b>	Withdrawal of a Tender between the deadline for submission of Tenders and the expiration of the period of Tender validity specified in the <b>Tender Data Sheet</b> or as extended pursuant to sub-Clause 22.2 shall result in the forfeiture of the Tender Security and execution of Tender Securing Declaration pursuant to ITT sub-Clause 19.9.
	<b>24.5</b>	Tenderers may only offer discounts to, or otherwise modify the prices of their Tenders by submitting Tender modifications in accordance with this Clause, or included in the original Tender submission.

### **E. Opening and Evaluation of Tenders**

<b>25. Opening of Tenders</b>	<b>25.1</b>	The Procuring Entity will open all Tenders including modifications, substitution or withdraw notices made pursuant to ITT Clause 24.
<b>26. Confidentiality</b>	<b>26.1</b>	Information relating to the examination, clarification, evaluation, and comparison of Tenders and recommendations for the award of a Contract shall not be disclosed to Tenderers or any other persons not officially concerned with such process until the award to the successful Tenderer has been announced.
	<b>26.2</b>	Any effort by a Tenderer to influence the Procuring Entity's processing of Tenders or award decisions may result in the rejection of his Tender.
	<b>26.3</b>	Notwithstanding sub-Clause 26.2, from the time of Tender opening to the time of Contract award, if any Tenderer wishes to contact the Procuring Entity on any matter related to the Tendering process, it should do so in writing.
<b>27. Clarification of Tenders</b>	<b>27.1</b>	To assist in the examination, evaluation, comparison of Tenders and post-qualification of the Tenderer, the Procuring Entity may, at its discretion, ask a Tenderer for clarification of its Tender including breakdown of prices. Any clarification submitted by a Tenderer that is not in response to a request by the Procuring Entity shall not be considered.
	<b>27.2</b>	The request for clarification and the response shall be in writing. No change in the prices or substance of the Tender shall be sought, offered, or permitted except to confirm the correction of arithmetic errors discovered by the Procuring Entity in the evaluation of Tenders in accordance with ITT Clause 29.

	<b>27.3</b>	From the time of Tender opening to the time of Contract award if any Tenderer wishes to contact the Procuring Entity on any matter related to the Tender it should do so in writing.		
<b>28. Mandatory Preliminary Examination of Tenders</b>	<b>28.1</b>	Prior to technical evaluation, the tenderers shall be subjected to mandatory preliminary evaluation using the below listed criteria. The evaluation shall be on YES/NO criteria and a tenderer must pass all below stated mandatory preliminary requirements in order to proceed to the next stage of technical evaluation. Any NO in any criteria shall result in overall FAIL:		
<b>S/N</b>	<b>Mandatory Eligibility criteria</b>	<i>Documents to be provided/completed</i>	<i>Tenderer's Compliance (YES or NO)</i>	
1	Provide documentary evidence of the company's Certificate of Incorporation or Business Registration Certificate (Legal structure)	Copy of Certificate of incorporation/ Business Registration Certificate		
2	Provide copy of the company's <b>current</b> Certificate of Tax Compliance issued by Kenya Revenue Authority (KRA) valid at least up to the date of tender opening.	Valid Certificate of Tax Compliance		
3	Submit a duly filled Form of Tender with a validity period of at least <b>140 days</b> in the format provided in the tender document.	Form of tender duly filled		
4	Duly filled Confidential Business Questionnaire (CBQ) in the format provided in this tender document	CBQ duly filled		
5	a) Copy of NCA 5''and above Certificate for General Building works b) Copy of NCA 5''and above Certificate for electrical works c) Valid NCA practicing license for above categories	Copy of Valid Certificate and practicing License issued by NCA Registration		
6	Provide audited accounts for the last three years (2021, 2022 and 2023). <b>OR</b> 6 Months signed and stamped bank statement as from November 2024	Audit report OR Bank statement		
7	Submit duly filled self-declaration forms as follows:	Duly filled Forms attached in Annex		

8	Provide documentary evidence of liquid assets and/or availability of credit facilities of a value of at least <b>Kshs.3 million (Kenya Shillings three Million)</b> . This should be demonstrated by attaching copies of certified bank statements for the last six months ( <b>From 1<sup>st</sup> June 2024 to 30<sup>th</sup> November 2024</b> ) <b>OR</b> Provide original reference letter from the bank addressed to the AIC Health Ministries showing proof of line of credit of not less 3,000,000.00 The documents so provided may be verified for authenticity).	Bank Statements or letter of line of credit	
9	Provide copy of Current Trade License	Copy of Current Trade License issued by the respective counties	
10	Attached CR12 to demonstrate that the Company is wholly owned and controlled by persons who are citizens of Kenya	Copy of CR12	

	<b>28.2</b>	The Procuring Entity will confirm that the documents and information specified under ITT Clause 12 and ITT Clause 13 have been provided in the Tender. If any of these documents or information is missing, or is not provided in accordance with the Instructions to Tenderers, the Tender shall be rejected.
	<b>28.3</b>	The Procuring Entity may waive any minor informality, nonconformity, or irregularity in a Tender which does not constitute a material deviation, provided such waiver does not prejudice or affect the relative ranking of any Tenderer
	<b>28.4</b>	A substantially responsive Tender is one which conforms to all the terms, conditions, and specifications of the Tendering documents, without material deviation or reservation. A material deviation or reservation is one that:  a) Affects in any substantial way the scope, quality, or execution of the Works;  b) Limits in any substantial way, inconsistent with the Tendering documents, the Procuring Entity's rights or the Tenderer's obligations under the Contract; or

		c) If rectified, would affect unfairly the competitive position of other Tenderers presenting substantially responsive Tenders.
	<b>28.5</b>	If a Tender is not substantially responsive, it will be rejected by the Procuring Entity, and may not subsequently be made responsive by correction or withdrawal of the non-conforming deviation or reservation.
<b>29. Correction of Errors</b>	<b>29.1</b>	<p>Tenders determined to be substantially responsive will be checked by the Procuring Entity for any arithmetic errors. Errors will be corrected by the Procuring Entity as follows:</p> <p>a) If there is a discrepancy between unit prices and the total price that is obtained by multiplying the unit price and quantity, the unit price shall prevail, and the total price shall be corrected, unless in the opinion of the Procuring Entity there is an obvious misplacement of the decimal point in the unit price, in which the total price as quoted shall govern and the unit price shall be corrected;</p> <p>b) If there is an error in a total corresponding to the addition or subtraction of subtotals, the subtotals shall prevail and the total shall be corrected; and</p> <p>c) Where there is a discrepancy between the amounts in figures and in words, the amount in words will govern.</p>
	<b>29.2</b>	The amount stated in the Tender will, be adjusted by the Procuring Entity in accordance with the above procedure for the correction of errors and, with, the concurrence of the Tenderer, shall be considered as binding upon the Tenderer. If the Tenderer does not accept the corrected amount, its Tender will then be rejected, and the Tender Security may be forfeited and the Tender Securing Declaration may be executed in accordance with sub-Clause 19.9.
<b>30. Conversion to Single Currency</b>	<b>30.1</b>	To facilitate the evaluation and comparison, the Procuring Entity will convert all Tender prices expressed in the amounts in various currencies in which the Tender prices are payable to Kenya Shillings at the selling exchange rate established for similar transactions by the Central Bank of Kenya ruling on the date specified in the <b>Tender Data Sheet</b> .
<b>31. Comparison of Tenders</b>	<b>31.1</b>	The Procuring Entity shall evaluate and compare only the Tenders determined to be substantially responsive in accordance with ITT Clause 28.
	<b>31.2</b>	<p>In evaluating the Tenders, the Procuring Entity will determine for each Tender the evaluated Tender price by adjusting the Tender price as follows:</p> <p>Making any correction for errors pursuant to ITT Clause 29;</p> <p>Excluding provisional sums and the provision, if any for contingencies in the Bill of Quantities, but including Day work, where priced competitively; and</p> <p>Making appropriate adjustments to reflect discounts or other price</p>

		modifications offered in accordance with sub-Clause 24.5.
	<b>31.3</b>	The Procuring Entity may waive any minor informality or non-conformity, which does not constitute a material deviation, provided such waiver does not prejudice or affect the relative standing of any Tenderer. Variations, deviations, and alternative offers and other factors, which are in excess of the requirements of the Tendering documents or otherwise result in unsolicited benefits for the Procuring Entity will not be considered in Tender evaluation.
<b>32. National Preference</b>	<b>32.1</b>	In the evaluation of Tenders, the Procuring Entity shall apply exclusive preference to citizens of Kenya
	<b>32.2</b>	To qualify for the preference the candidate shall provide evidence of eligibility by: <ul style="list-style-type: none"> <li>a) Proving Kenyan citizenship by production of a Kenyan Identity Card; or</li> <li>b) Providing proof of being a “citizen contractor” in terms of section 3(1) of the Act, i.e. being a natural person or an incorporated company wholly owned and controlled by persons who are citizens of Kenya.</li> </ul>
<b>33. Determination of the winning Bidder</b>	<b>33.1</b>	Tenderers will be required to score 75% and above on the Technical Evaluation to qualify for Financial Evaluation.  Tenderers scoring 75% and above under the technical evaluation on qualification will be subjected to financial evaluation. This will involve checking for completeness of the Bill of Quantities and ranking of the bids to determine the lowest evaluated bidder.  The lowest evaluated bidder will be recommended for consideration of award of the tender.
<b>34. Post-qualification of Tenderer</b>	<b>34.1</b>	If specified in the <b>Tender Data Sheet</b> , post-qualification shall be undertaken.
	<b>34.2</b>	The Procuring Entity will determine to its satisfaction whether the Tenderer that is selected as having submitted the lowest evaluated responsive Tender is qualified to perform the contract satisfactorily, in accordance with the criteria listed in sub-Clause 13.3.
	<b>34.3</b>	The determination will consider the Tenderer’s financial, technical, and production capabilities. It will be based upon an examination of the documentary evidence of the Tenderer’s qualifications submitted by the Tenderer, pursuant to sub-Clause 13.3, as well as such other information as the Procuring Entity deems necessary and appropriate. Factors not included in these Tendering documents shall not be used in the evaluation of the Tenderer’s qualifications.

	<b>34.4</b>	An affirmative determination will be a prerequisite for award of the contract to the Tenderer. A negative determination will result in rejection of the Tenderer's Tender, in which event the Procuring Entity will proceed to the next lowest evaluated Tender to make a similar determination of that Tenderer's capabilities to perform satisfactorily.
--	-------------	--

## F. Award of Contract

<b>35. Criteria of Award</b>	<b>35.1</b>	<p>Subject to ITT Clause 35 and 36, the Procuring Entity will award the Contract to the Tenderer whose Tender has been determined to be substantially responsive to the Tendering documents. The technical evaluation is weighted out of 100% Tenderers scoring 75% and above under the technical evaluation on qualification will be subjected to financial evaluation. This will involve checking for completeness of the Bill of Quantities and ranking of the bids to determine the lowest evaluated bidder.</p> <p>The lowest evaluated bidder will be recommended for consideration of award of the tender.</p> <p>Tenderer has been determined to be:</p> <ul style="list-style-type: none"> <li>a) Eligible in accordance with the provisions of ITT Clause 3;</li> <li>b) Is determined to be qualified to perform the Contract satisfactorily;</li> </ul>
	<b>35.2</b>	If, pursuant to sub-Clause 14.1, this Contract is being awarded as a single Tender.
<b>36. Clarifications</b>	<b>36.1</b>	<p>Clarifications may be undertaken with the most competitive Tenderer relating to the following areas:</p> <ul style="list-style-type: none"> <li>a) A minor alteration to the technical details of the statement of requirements;</li> <li>b) Reduction of quantities for budgetary reasons, where the reduction is in excess of any provided for in the Tendering documents;</li> <li>c) A minor amendment to the Contract Data Sheet;</li> <li>d) Finalizing payment arrangements;</li> <li>e) Mobilization arrangements;</li> <li>f) Agreeing final delivery or work schedule to accommodate any changes required by the Procuring Entity;</li> <li>g) The methodology or staffing; or</li> </ul>



		h) Clarifying details that were not apparent or could not be finalized at the time of Tendering.
	<b>36.2</b>	Clarifications shall not change the substance OR price of the tender.
<b>37. Procuring Entity's Right to Accept any Tender and to Reject any or all Tenders</b>	<b>37.1</b>	Notwithstanding ITT Clause 35, the Procuring Entity reserves the right to accept or reject any Tender, and to cancel the Tendering process and reject all Tenders, at any time prior to the award of Contract, without thereby incurring any liability to the affected Tenderer or Tenderers.
	<b>37.2</b>	Notice of the rejection of all Tenders shall be given promptly within 14 days to all Contractors that have submitted Tenders.
	<b>37.3</b>	The Procuring Entity shall upon request communicate to any Tenderer the grounds for its rejection of its Tenders, but is not required to justify those grounds.
<b>38. Procuring Entities Right to Vary Quantities at the Time of Award</b>	<b>38.1</b>	The Procuring Entity reserves the right at the time of contract award to increase or decrease the quantity of goods or related services originally specified in these Tendering documents (schedule of requirements) provided this does not exceed by the percentage indicated in the <b>Tender Data Sheet</b> , without any change in unit price or other terms and conditions of the Tender and Tendering documents.
<b>39. Notification of Award</b>	<b>39.1</b>	The Tenderer whose Tender has been accepted will be notified of the award by the Procuring Entity prior to expiration of the Tender validity period by e-mail confirmed by registered letter. This letter (hereinafter and in the Conditions of Contract called the "Letter of Acceptance") will state the sum that the Procuring Entity will pay the Contractor in consideration of the provision of construction works as prescribed by the Contract (hereinafter and in the Contract called the "Contract Price").
	<b>39.2</b>	The notification of award will constitute the formation of the Contract, subject to the Tenderer furnishing the Performance Security in accordance with ITT Clause 41 and signing the Contract in accordance with sub-Clause 40.2
	<b>39.3</b>	At the same time as the person submitting the successful Tender is notified, the Procuring Entity will notify each unsuccessful Tenderer, the name of the successful Tenderer and the Contract amount and will discharge the Tender Security and Tender Securing Declaration of the Tenderer pursuant to ITT sub Clause 19.7.
	<b>39.4</b>	If, after notification of award, a Tenderer wishes to ascertain the grounds on which it's Tender or application for pre-qualification was unsuccessful, it should address its request to the secretary of the Tender Committee that authorized the award of contract. The secretary of the Tender Committee

		shall, within fourteen days after a request, provide written reasons as to why the Tender, proposal or application to be pre-qualified was unsuccessful.
<b>40. Signing of Contract</b>	<b>40.1</b>	Promptly, and in no case later than 14 days, after notification, Procuring Entity shall send the successful Tenderer the Agreement and Contract Data Sheet, incorporating all agreements between the parties
	<b>40.2</b>	Within the period specified in the notification or Tender Data Sheet but not earlier than fourteen (14) days since notification of award of contract, the successful Tenderer shall sign and date the contract and return it to the Procuring Entity.
<b>41. Performance Security- NOT REQUIRED FOR THIS TENDER</b>	<b>41.1</b>	Within thirty (10) days but not after 14 days after receipt of the Letter of Acceptance, the successful Tenderer shall deliver to the Procuring Entity a Performance Security in the amount and in the form stipulated in the Tender Data Sheet and the Contract Data Sheet, denominated in the type and proportions of currencies in the Letter of Acceptance and in accordance with the Conditions of Contract.
	<b>41.2</b>	If the Performance Security is provided by the successful Tenderer in the form of a Bank Guarantee or Insurance Bond, it shall be issued either:  a) At the Tenderer's option, by a bank or insurance firm located in Kenya, or a foreign bank or insurance firm through a correspondent bank or insurance firm located in Kenya;
	<b>41.3</b>	Failure of the successful Tenderer to comply with the requirement of sub-Clause 41.1 shall constitute sufficient grounds for the annulment of the award and forfeiture of the Tender Security, in which event the Procuring Entity may make the award to the next lowest evaluated Tenderer or call for new Tenders.
<b>42. Advance Payment</b>	<b>42.1</b>	No advance payment will be issued. Payment to be based on performance, achievement of milestones and issue of completion certificates.

TDS Reference Number	ITT Clause Number	Amendments of, and Supplements to, Clauses in the Instruction to Tenderers
<b>A. Introduction</b>		
1.	1.1	The Procuring Entity is Africa Inland Church Health Ministries (AICHM)
2.	1.1	Name of Project is  <b>FABRICATION, SUPPLY AND INSTALLATION OF 40FT CONTAINERS</b>
3.	1.2	The expected completion date of the works is 31 <sup>st</sup> January 2025
4.	1.3	The Objectives of the Project is <b>FABRICATION, SUPPLY AND INSTALLATION OF 40FT CONTAINERS</b>
5.	2.1	Name of financing institution is Africa Inland Church Health Ministries (AICHM) through Malteser International  Name of the Procuring is Africa Inland Church Health Ministries (AICHM)
6.	5.1	Alternative Tenders are <i>“not allowed”</i> in this Tender.
7.	3.1	Only Tenderers who are citizen contractors are eligible
8.	7.3	Pre-Tender meeting shall not be held.

## SECTION III: TENDER DATA SHEET

### Tender Data Sheet (TDS)

#### Instructions to Tenderers Clause Reference

B. Tendering Documents		
9.	8.1	Address for clarification of Tendering Document is <a href="mailto:inquiry@aichm.org">inquiry@aichm.org</a>
10.	8.2	Period to Respond to request for clarification by the Procuring Entity <i>2 days</i>

C. Preparation of Tenders		
11.	11.1	Language of Tender and all correspondence shall be <i>English</i>
12.	12.1	Prior to mandatory preliminary evaluation, the tenderers shall be subjected to <b>TENDERER'S ELIGIBILITY- by filling the CONFIDENTIAL BUSINESS QUESTIONNAIRE</b> Provided in the annex.

#### Stage 2: Technical Responsiveness Evaluation Stage

Tenders will be evaluated to ensure that they are substantially responsive to the technical specifications and contract conditions stated in the Tender Document. The determination of a tender's technical responsiveness will be based on the contents of the tender itself, subject to any clarifications received in the preliminary examination of Tenders. Items of this evaluation will be scored.

#### Technical Evaluation Criteria

The technical evaluation is weighted out of 100 with a pass mark of 75%.

Any bidder scoring 75% and above in the technical evaluation will proceed to the financial evaluation stage.

Evaluation Criteria	Requirements	Proof	Score
<b>1.Experience of the Firm</b>	Provide evidence of at least four (4) similar assignments in relation to welding and fabrication undertaken over the last Five (5) years. The assignments submitted above, must detail the organization name and address, contact person(s), contact details, contract amount and a detailed outline of the assignment undertaken with at least two project related to container fabrication	a) Submit a <b>LIST</b> of four similar assignments. Detail the organization name and address, contact person(s), contact details, contract amount- ( <b>2 marks</b> ) b) Submit four (4) work orders/contracts for the assignments listed in (a) above. Each 4 marks- ( <b>16 marks</b> ) c) Submit recommendation Letters /Completion certificates from the four (4) clients listed in (b) above each with photos. Each 4 marks –( <b>16 marks</b> )	34

<b>2.Education Qualification</b>	Degree/Diploma in Building/Construction/Engineering works related field for any company Director as per CR12.	Attach CVs signed by the director indicating experience at least 2 years- <b>2 marks</b> Attach Copy of Degree/Diploma in construction related field - <b>3 marks</b>	5
	At least Diploma/ Certificate in Building works or related field for the Foreman	<input type="checkbox"/> Attach copies of relevant certificate <b>2 marks</b> <input type="checkbox"/> Attach CV signed by the foreman indicating previous experience <b>3 marks</b> <input type="checkbox"/> Valid NCA registration as construction supervisor <b>5 marks</b>	10
	At least Diploma/ Certificate in Electrical works or related field for the Electrician	<input type="checkbox"/> Attach copies of relevant certificate <b>2 marks</b> <input type="checkbox"/> Attach CV signed by the foreman indicating previous experience <b>3 marks</b> <input type="checkbox"/> Valid EPRA certification at least C1 <b>6 marks</b>	11
	Craft/ certificate/Trade Test for: 1. Carpenter 2. Welder 3. Painter	Attach copies of Government trade test/artisan/Craft certificates or any relevant certificate 3 marks for each certificate. <b>(Total 9 marks)</b> and attach signed CV by the owners indicating previous works <b>3 marks each. (Total 9 marks)</b>	18

<b>Evaluation Criteria</b>	<b>Requirements</b>	<b>Proof</b>	<b>Score</b>
<b>Financial Capacity</b>	Proof of Financial Capacity to execute the contract if awarded the tender	Bidders must have an average Annual turnover of <b>at least Kshs. 3 million</b> as per the bidder's Annual Audited Accounts for the three (3) years OR documentary evidence of liquid assets and/or availability of credit facilities of a value of at least Kshs.3 million (Kenya Shillings three Million). This should be demonstrated by attaching copies of certified bank statements for the last six months (From 1st June 2024 to 30th November 2024) OR Provide original reference letter from the bank addressed to the AIC Health Ministries showing proof of line of credit of not less 3,000,000.00. <b>Max. 10 marks.</b>	10

<b>4. Works Completion Cmmitment</b>	Commitment to execute the works within 1 month	Company's signed and stamped commitment letter.	6
<b>5. Work Plan/ methodology</b>	The bidders should provide a detailed Ghant chart work plan	<p>Bidders must submit Ghant chart using <b>MS Project</b> (6mks) or any drawn table scheduling.</p> <ul style="list-style-type: none"> <li><input type="checkbox"/> All the activities (Deliverables) 2mks)</li> <li><input type="checkbox"/> Desired timelines (2mks)</li> <li><input type="checkbox"/> Overall project time (1mks)</li> <li><input type="checkbox"/> Resource (human and equipment) allocations (1mks)</li> </ul> <p><b>Note:</b> Work Plan not meeting the above threshold will not be considered, leading to disqualification on this item.</p>	6
<b>Total scores</b>			<b>100</b>

Tenderers will be required to **score 75% and above** on the above Technical Evaluation to qualify for Financial Evaluation.

#### **Financial Evaluation**

The bids that qualify at the Technical Capacity Evaluation stage will be subjected to financial evaluation to determine the winner. The lowest cost evaluated bidder based on the form of tender will be considered for award of tender

#### **Notes:**

- i. Bidder should dully fill the price schedule and transfer total to form of tender*
- ii. Prices quoted must be in **KENYA SHILLINGS** and inclusive of all incidental costs and applicable taxes.*
- iii. Bidders **MUST** ensure that their bids are arithmetic error free*
- iv. Bidders **MUST** ensure that all calculations are estimated to two decimal places.*

#### **Recommendation of Award**

The lowest evaluated bidder will be recommended for consideration of award of the tender.

<b>13.</b>	<b>13.1</b>	The price shall be <i>fixed</i>
<b>14.</b>	<b>14.1</b>	The currency in which the prices shall be quoted shall be: <i>Kenyan Shilling</i>
<b>16.</b>	<b>16.1</b>	The authority for establishing the rates of exchange shall be Central Bank of Kenya.  The applicable date for exchange rates for tendering and evaluation purposes is 28 days

		earlier than the final deadline for the submission of tenders.
17.	17.1	The Tender validity period shall be 140 days.
18.	18.1	Tender Securing Declaration is not required
19.	19.1	Written confirmation of authorization as provided <i>[power of attorney]</i>
<b>D. Submission of Tenders</b>		
20.	20.1	Tenders shall be submitted to: Africa Inland Church Health Ministries (AICHM) Through;  <a href="mailto:tenders@aichm.org">tenders@aichm.org</a>
21.	21.1	Project name <b>FABRICATION, SUPPLY AND INSTALLATION OF 40FT CONTAINERS</b>  Tender number <b>AICHM/MI/CONT/091124</b> Time and date for submission 5:00 PM 24 <sup>th</sup> December 2024
22.	22.1	The deadline for Tender submission is a) Day 24 <sup>th</sup> b) December 2024 c) Time 5:00 PM
23	23.1	Expiry of Tender validity is 140 days after submission deadline.
<b>E. Opening and Evaluation of Tenders</b>		
24.	24.1	The Tender opening shall take place at: Africa Inland Church Health Ministries (AICHM) offices in Upperhil
<b>F. Award of Contract</b>		
25.	25.1	No advance payment will be issued. Payment to be based on performance, achievement of milestones and issue of completion certificates.

## **IV: GENERAL CONDITIONS OF CONTRACT**



## TABLE OF CLAUSES

ABBREVIATIONS AND ACRONYMS .....	6
SECTION I: INVITATION FOR TENDERS (IFT) .....	7
SECTION II: INSTRUCTIONS TO TENDERERS (ITT).....	8
A. Introduction .....	11
1. Scope of Tender.....	11
2. Source of Funds.....	11
3. Eligible Tenderers.....	11
4. One Tender per Tenderer.....	12
5. Alternative Tenders by Tenderers .....	12
6. Cost of Tendering .....	12
7. Site Visit and Pre-Tender Meeting .....	12
B. Tendering Documents .....	13
8. Content of Tendering Documents.....	13
9. Clarification of Tendering Documents .....	14
10. Amendments of the Tendering Documents .....	14
C. Preparation of Tenders .....	14
11. Language of Tender.....	14
12. Documents Constituting the Tender .....	14
13. Documents Establishing Eligibility and Qualifications of the Tenderer .....	15
14. Lots Package.....	16
15. Form of Tender.....	16
16. Tender Prices .....	16
17. Tender Currencies.....	16
18. Tender Validity Period .....	17
19. Tender Securing Declaration -NOT REQUIRED FOR THIS TENDER .....	17
20. Format and Signing of Tender.....	17
D. Submission of Tenders .....	18
21. Sealing and Marking of Tenders .....	18
22. Deadline for Submission of Tenders .....	18
23. Late Tenders .....	18
24. Modification, Substitution and Withdrawal of Tenders .....	18
E. Opening and Evaluation of Tenders.....	19
25. Opening of Tenders .....	19
26. Confidentiality .....	19
27. Clarification of Tenders.....	19
28. Mandatory Preliminary Examination of Tenders .....	20
29. Correction of Errors.....	22
30. Conversion to Single Currency.....	22
31. Comparison of Tenders .....	22
32. National Preference .....	23
33. Determination of the winning Bidder .....	23
34. Post-qualification of Tenderer .....	23
F. Award of Contract.....	24
35. Criteria of Award.....	24
36. Clarifications .....	24
37. Procuring Entity's Right to Accept any Tender and to Reject any or all Tenders..	25
38. Procuring Entities Right to Vary Quantities at the Time of Award.....	25
39. Notification of Award.....	25
40. Signing of Contract.....	26
41. Performance Security- NOT REQUIRED FOR THIS TENDER .....	26
42. Advance Payment.....	26
SECTION III: TENDER DATA SHEET .....	28
IV: GENERAL CONDITIONS OF CONTRACTTable of Clauses.....	32
A. General .....	36

1.	Definitions .....	36
2.	Interpretation .....	37
3.	Language, Law, Fraud and Corruption.....	38
4.	Confidentiality .....	39
5.	Project Manager’s Decisions .....	39
6.	Delegation.....	39
7.	Communications .....	39
8.	Subcontracting.....	39
9.	Other Contractors .....	39
10.	Personnel .....	39
11.	Procuring Entity’s and Contractor’s Risks .....	39
12.	Procuring Entity’s Risks.....	39
13.	Contractor’s Risks .....	40
14.	Site Investigation Reports.....	40
15.	Queries about the Contract Data Sheet.....	40
16.	Contractor to Construct the Works .....	40
17.	Commencement and Completion .....	40
18.	Approval by the Project Manager.....	40
19.	Protection of the Environment.....	40
20.	Labour Laws.....	40
21.	Health and Safety.....	40
22.	Discoveries .....	41
23.	Possession of the Site .....	41
24.	Access to the Site.....	41
25.	Instructions, Inspections and Audits.....	41
<b>B.</b>	<b>Time Control .....</b>	<b>41</b>
26.	Programme .....	41
27.	Extension of the Intended Completion Date.....	41
28.	Acceleration.....	42
29.	Delays Ordered by the Project Manager.....	42
30.	Management Meetings .....	42
31.	Early Warning.....	42
<b>C.</b>	<b>Quality Control.....</b>	<b>42</b>
32.	Identifying Defects .....	42
33.	Tests.....	42
34.	Correction of Defects.....	42
35.	Uncorrected Defects .....	42
<b>D.</b>	<b>Cost Control .....</b>	<b>43</b>
36.	Bill of Quantities .....	43
37.	Cash Flow Forecasts.....	43
38.	Payment Certificates.....	43
39.	Payments.....	43
40.	Compensation Events .....	43
41.	Taxes.....	44
42.	Currencies.....	44
43.	Price Adjustment .....	44
44.	Liquidated Damages.....	44
45.	Performance Securities -Will Not Be required for this Tender .....	44
46.	Cost of Repairs .....	45
<b>E.</b>	<b>Finishing the Contract .....</b>	<b>45</b>
47.	Completion Certificate .....	45
48.	Taking Over.....	45
49.	Final Account .....	45
50.	Operating and Maintenance Manuals .....	45
51.	Termination .....	45
52.	Payment upon Termination .....	46
53.	Property .....	46
54.	Release from Performance.....	46

55. Suspension of Financing.....	46
SECTION V: CONTRACT DATA SHEET (CDS) .....	47
SECTION VI: TECHNICAL SPECIFICATIONS .....	51
SECTION VII: DRAWINGS .....	57
<i>SECTION VIII: BILL OF QUANTITIES</i> .....	58
SECTION IX: TENDER FORMS .....	74
A. Form of Tender.....	74
B. Tender-Securing Declaration .....	76
C. Confidential Business Questionnaire .....	77

## A. General

### 1. Definitions

Boldface type is used to identify defined terms.

The **Adjudicator** is the person appointed jointly by the Procuring Entity and the Contractor to resolve disputes in the first instance, as provided for in Clauses 27 and 28 hereunder.

**Bill of Quantities** means the priced and completed Bill of Quantities forming part of the Tender.

**Compensation Events** are those defined in Clause 47 hereunder.

The **Completion Date** is the date of completion of the Works as certified by the Project Manager, in accordance with Sub-Clause 58.1.

The **Contract** is the Contract between the Procuring Entity and the Contractor to execute, complete, and maintain the Works. It consists of the documents listed in Clause 2.3 below.

The **Contractor** is a person or corporate body whose Tender to carry out the Works has been accepted by the Procuring Entity.

The **Contractor's Tender** is the completed Tendering document submitted by the Contractor to the Procuring Entity.

The **Contract Price** is the price stated in the Letter of Acceptance and thereafter as adjusted in accordance with the provisions of the Contract.

**Days** are calendar days; months are calendar months.

**Dayworks** are varied work inputs subject to payment on a time basis for the Contractor's employees and Equipment, in addition to payments for associated Materials and Plant.

A **Defect** is any part of the Works not completed in accordance with the Contract.

The **Defects Liability Certificate** is the certificate issued by the Project Manager upon correction of defects by the Contractor.

The **Defects Liability Period** is the period named in the **Contract Data Sheet** and calculated from the Completion Date.

**Drawings** include calculations and other information provided or approved by the Project Manager for the execution of the Contract.

The **Procuring Entity** is the party who employs the Contractor to carry out the Works.

**Equipment** is the Contractor's machinery and vehicles brought temporarily to the Site to construct the Works.

The **Initial Contract Price** is the Contract Price listed in the Procuring Entity's Letter of Acceptance.

The **Intended Completion Date** is the date on which it is intended that the Contractor

	<p>shall complete the Works. The Intended Completion Date is specified in the <b>Contract Data Sheet</b>. The Intended Completion Date may be revised only by the Project Manager by issuing an extension of time or an acceleration order.</p> <p><b>Materials</b> are all supplies, including consumables, used by the Contractor for incorporation in the Works.</p> <p><b>Plant</b> is any integral part of the Works that shall have a mechanical, electrical, chemical, or biological function.</p> <p>The <b>Project Manager</b> is the person named in the <b>Contract Data Sheet</b> (or any other competent person appointed by the Procuring Entity and notified to the Contractor, to act in replacement of the Project Manager) who is responsible for supervising the execution of the Works and administering the Contract.</p> <p>The <b>Site</b> is the area defined as such in the <b>Contract Data Sheet</b>.</p> <p><b>Site Investigation Reports</b> are those that were included in the Tendering documents and are factual and interpretative reports about the surface and subsurface conditions at the Site.</p> <p><b>Specification</b> means the Specification of the Works included in the Contract and any modification or addition made or approved by the Project Manager.</p> <p>The <b>Start Date</b> is given in the <b>Contract Data Sheet</b>. It is the latest date when the Contractor shall commence execution of the Works. It does not necessarily coincide with any of the Site Possession Dates.</p> <p>A <b>Subcontractor</b> is a person or corporate body who has a Contract with the Contractor to carry out a part of the work in the Contract, which includes work on the Site.</p> <p><b>Temporary Works</b> are works designed, constructed, installed, and removed by the Contractor that are needed for construction or installation of the Works.</p> <p>A <b>Variation</b> is an instruction given by the Project Manager that varies the Works.</p> <p>The <b>Works</b> are what the Contract requires the Contractor to construct, install, and turn over to the Procuring Entity, as defined in the <b>Contract Data Sheet</b>.</p> <p>“<b>Force Majeure</b>” means an event which is beyond the reasonable control of a Party and which makes a Party’s performance of its obligations under the Contract impossible or so impractical as to be considered impossible under the circumstances.</p>
<p><b>2. Interpretation</b></p>	<p>In interpreting these Conditions of Contract, singular also means plural, male also means female or neuter, and the other way around. Headings have no significance. Words have their normal meaning under the language of the Contract unless specifically defined. The Project Manager will provide instructions clarifying queries about these Conditions of Contract.</p> <p>If sectional completion is specified in the <b>Contract Data Sheet</b>, references in the Conditions of Contract to the Works, the Completion Date, and the Intended Completion Date apply to any Section of the Works (other than references to the</p>

	<p>Completion Date and Intended Completion Date for the whole of the Works).</p> <p>2.3 The documents forming the Contract shall be interpreted in the order of priority given in the <b>Contract Data Sheet</b>:</p> <p>Agreement;  Letter of Acceptance;  Contract Data Sheet;  Conditions of Contract;  Technical Specifications;  Contractor’s Tender;  Drawings;  Bill of Quantities; and  Any other document listed in the <b>Contract Data Sheet</b> as forming part of the Contract.</p>
<p><b>3. Language, Law, Fraud and Corruption</b></p>	<p>3.1 The language of the Contract and the law governing the Contract are stated in the <b>Contract Data Sheet</b>.</p>
	<p>3.2 It is the responsibility of the Procuring Entity to ensure that Tenderers, suppliers, and contractors and their subcontractors observe the highest standard of ethics during the procurement and execution of such contracts. In pursuance of this policy:</p> <p>For the purpose of this provision, the following definitions are provided:</p> <p>“<b>Corruption</b>” has the meaning assigned to it in the Anti-Corruption and Economic Crime Act 2003 and includes the offering, giving, receiving or soliciting of anything of value to influence the action of a public official in the procurement or disposal process or in contract execution;</p> <p>“<b>Fraudulent Practice</b>” includes a misrepresentation of fact in order to influence a procurement or disposal process or the execution of a contract to the detriment of the Procuring Entity and includes collusive practices amongst Tenderers prior to or after Tender submission designed to establish Tender prices at artificial non-competitive levels and deprive the Procuring Entity of the benefits of free and open competition;</p> <p>“<b>Collusive Practice</b>” means an arrangement between two or more suppliers, contractors and subcontractors designed to achieve an improper purpose, including to influence improperly the actions of the Procuring Entity prior to or after Tender submission, designed to establish Tender prices at artificial non-competitive levels and to deprive the Procuring Entity of the benefit of free and open competition;</p> <p>“<b>Coercive Practice</b>” means impairing or harming, or threatening to impair or harm, directly or indirectly a supplier, contractor or subcontractor or the property of any of them to influence improperly the actions of a Procuring Entity;</p> <p>“<b>Obstructive Practice</b>” means deliberately destroying, falsifying, altering or concealing of evidence material to the investigation or making false statements to investigators in order to materially impede an investigation into allegations of a corrupt, fraudulent, coercive or collusive practice; and /or threatening, harassing or intimidating any party to prevent it from disclosing its knowledge of matters relevant to the investigation or from pursuing the investigation.</p> <p>The Procuring Entity will reject a proposal for award if it determines that the Tenderer recommended for award has engaged in corrupt, fraudulent practices or others stated under Clause 44.1.a in competing for the contract;</p> <p>In pursuit of the policy defined in sub-Clause 44.1 the Procuring Entity will cancel the portion of the funds allocated to a contract for goods, works, or</p>

	services if it at any time determines that corrupt or fraudulent practices were engaged in by representatives of the Procuring Entity or Approving Authority or of a beneficiary of the funds during the procurement or the execution of that contract.
	3.3 Any communication between the Tenderers and the Procuring Entity related to matters of alleged fraud or corruption must be made in writing.
<b>4. Confidentiality</b>	The Service Providers, their Subcontractors, and the Personnel of either of them shall not disclose any proprietary or confidential information relating to the Project, the Services, this Contract, or the Procuring Entity's business or operations without the prior written consent of the Procuring Entity.
<b>5. Project Manager's Decisions</b>	Except where otherwise specifically stated, the Project Manager will decide contractual matters between the Procuring Entity and the Contractor in the role representing the Procuring Entity.
<b>6. Delegation</b>	The Project Manager may delegate any of his duties and responsibilities to other people except to the Adjudicator, after notifying the Contractor, and may cancel any delegation after notifying the Contractor.
<b>7. Communications</b>	Communications between parties that are referred to in the Conditions shall be effective only when in writing. A notice shall be effective only when it is delivered.
<b>8. Subcontracting</b>	The Contractor may subcontract with the approval of the Project Manager, but may not assign the Contract without the approval of the Procuring Entity in writing. Subcontracting shall not alter the Contractor's obligations.
<b>9. Other Contractors</b>	The Contractor shall cooperate and share the Site with other contractors, public/county authorities, utilities, and the Procuring Entity between the dates given in the Schedule of Other Contractors, as referred to in the Contract Data Sheet. The Contractor shall also provide facilities and services for them as described in the Schedule. The Procuring Entity may modify the Schedule of Other Contractors, and shall notify the Contractor of any such modification
<b>10. Personnel</b>	<p>The Contractor shall employ the key personnel named in the Schedule of Key Personnel, as referred to in the Contract Data Sheet, who shall be appropriately qualified and registered with the appropriate bodies to carry out the functions stated in the Schedule or other personnel approved by the Project Manager. The Project Manager will approve any proposed replacement of key personnel only if their relevant qualifications and abilities are substantially equal to or better than those of the personnel listed in the Schedule.</p> <p>If the Project Manager asks the Contractor to remove a person who is a member of the Contractor's staff or work force, stating the reasons, the Contractor shall ensure that the person leaves the Site within seven days and has no further connection with the work in the Contract.</p>
<b>11. Procuring Entity's and Contractor's Risks</b>	The Procuring Entity carries the risks which this Contract states are Procuring Entity's risks, and the Contractor carries the risks which this Contract states are Contractor's risks.
<b>12. Procuring Entity's Risks</b>	<p>12.1 From the Start Date until the Defects Correction Certificate has been issued, the following are Procuring Entity's risks:</p> <p>The risk of personal injury, death, or loss of or damage to property (excluding the Works, Plant, Materials, and Equipment), which are due to:</p> <p>Use or occupation of the Site by the Works or for the purpose of the Works, which is the unavoidable result of the Works; or</p> <p>Negligence, breach of statutory duty, or interference with any legal right by the Procuring Entity or by any person employed by or contracted to him except the Contractor.</p> <p>The risk of damage to the Works, Plant, Materials, and Equipment to the extent that it</p>

	<p>is due to a fault of the Procuring Entity or in the Procuring Entity's design, or due to war or radioactive contamination directly affecting the country where the Works are to be executed.</p> <p>12.2 From the Completion Date until the Defects Correction Certificate has been issued, the risk of loss of or damage to the Works, Plant, and Materials is a Procuring Entity's risk except loss or damage due to:  A Defect which existed on the Completion Date;  An event occurring before the Completion Date, which was not itself a Procuring Entity's risk; or  The activities of the Contractor on the Site after the Completion Date.</p>
<b>13. Contractor's Risks</b>	13.1 From the Starting Date until the Defects Correction Certificate has been issued, the risks of personal injury, death, and loss of or damage to property (including, without limitation, the Works, Plant, Materials, and Equipment) which are not Procuring Entity's risks are Contractor's risks.
<b>14. Site Investigation Reports</b>	14.1 The Contractor, in preparing the Tender, shall rely on any Site Investigation Reports referred to in the Contract Data Sheet, supplemented by any information available to the Tenderers.
<b>15. Queries about the Contract Data Sheet</b>	15.1 The Project Manager will clarify queries on the Contract Data Sheet.
<b>16. Contractor to Construct the Works</b>	16.1 The Contractor shall construct and install the Works in accordance with the Specifications and Drawings.
<b>17. Commencement and Completion</b>	17.1 The Contractor may commence execution of the Works on the Start Date and shall carry out the Works in accordance with the Programme submitted by the Contractor, as updated with the approval of the Project Manager, and complete them by the Intended Completion Date.
<b>18. Approval by the Project Manager</b>	<p>18.1 The Contractor shall submit Specifications and Drawings showing the proposed Temporary Works to the Project Manager, who is to approve them if they comply with the Specifications and Drawings.</p> <p>18.2 The Contractor shall be responsible for the design of Temporary Works.</p> <p>18.3 The Project Manager's approval shall not alter the Contractor's responsibility for design of the Temporary Works.</p> <p>18.4 The Contractor shall obtain approval of third parties to the design of the Temporary Works, where required.</p> <p>18.5 All Drawings prepared by the Contractor for the execution of the temporary or permanent Works, are subject to prior approval by the Project Manager before their use.</p>
<b>19. Protection of the Environment</b>	19.1 The Contractors shall take all reasonable steps to protect the environment and to limit damage and nuisance to people and property resulting from pollution, noise and other results of his operations.
	19.2 The Contractors shall ensure that emissions, surface discharges and effluent from his activities shall not exceed prescribed values in the environmental laws.
<b>20. Labour Laws</b>	<p>20.1 The Contractor shall comply with all the relevant labour laws applicable in the Country, including laws relating to workers employment, working hours, health, safety, welfare, and immigration, and shall allow them all their legal rights.</p> <p>The Contractor shall require his employees to obey all applicable laws, including those concerning safety at work.</p>
<b>21. Health and Safety</b>	<p>21.1 The Contractor shall at all times take all reasonable precautions to maintain the health and safety of his personnel.</p> <p>21.2 The Contractor shall ensure that first aid facilities are available at all times at the site and that suitable arrangements are made for all necessary welfare and hygiene requirements and for the prevention of epidemics.</p> <p>21.3 The Contractor shall notify the Procuring Entity details of any accident as soon as practicable after its occurrence. The Contractor shall maintain records and</p>



	<p>make reports concerning health, safety, and welfare of persons, and damage to the property, as the Procuring Entity may reasonably require.</p> <p>21.4 The Contractor shall conduct an HIV-Aids awareness programme, and shall take other such measures as specified in the <b>Contract Data Sheet</b> to reduce the risk of transfer of HIV virus between and among Contractor personnel, the Procuring Entity's Staff and the surrounding community.</p>
<b>22. Discoveries</b>	22.1 Anything of historical or other interest or of significant value unexpectedly discovered on the Site shall be the property of the Procuring Entity. The Contractor shall notify the Project Manager of such discoveries and carry out the Project Manager's instructions for dealing with them.
<b>23. Possession of the Site</b>	23.1 The Procuring Entity shall give possession of all parts of the Site to the Contractor. If possession of a part is not given by the date stated in the <b>Contract Data Sheet</b> , the Procuring Entity will be deemed to have delayed the start of the relevant activities, and this will be a Compensation Event.
<b>24. Access to the Site</b>	24.1 The Contractor shall allow the Project Manager and any person authorized by the Project Manager access to the Site and to any place where work in connection with the Contract is being carried out or is intended to be carried out.
<b>25. Instructions, Inspections and Audits</b>	25.1 The Contractor shall carry out all instructions of the Project Manager which comply with the applicable laws where the Site is located.

### B. Time Control

<b>26. Programme</b>	<p>26.1 Within the time stated in the <b>Contract Data Sheet</b>, the Contractor shall submit to the Project Manager for approval a Programme showing the general methods, arrangements, order, and timing for all the activities in the Works.</p> <p>An update of the Programme shall be a programme showing the actual progress achieved on each activity and the effect of the progress achieved on the timing of the remaining work, including any changes to the sequence of the activities.</p> <p>26.2 The Contractor shall submit to the Project Manager for approval an updated Programme at intervals no longer than the period stated in the <b>Contract Data Sheet</b>. If the Contractor does not submit an updated Programme within this period, the Project Manager may withhold the amount stated in the <b>Contract Data Sheet</b> from the next payment certificate and continue to withhold this amount until the next payment after the date on which the overdue Programme has been submitted.</p> <p>26.3 The Project Manager's approval of the Programme shall not alter the Contractor's obligations. The Contractor may revise the Programme and submit it to the Project Manager again at any time. A revised Programme shall show the effect of Variations and Compensation Events</p>
<b>27. Extension of the Intended Completion Date</b>	<p>27.1 The Project Manager shall extend the Intended Completion Date if a Compensation Event occurs or a Variation is issued which makes it impossible for Completion to be achieved by the Intended Completion Date without the Contractor taking steps to accelerate the remaining work, which would cause the Contractor to incur additional cost.</p> <p>27.2 The Project Manager shall decide whether and by how much to extend the Intended Completion Date within 21 days of the Contractor asking the Project Manager for a decision upon the effect of a Compensation Event or Variation and submitting full supporting information. If the Contractor has failed to give early warning of a delay or has failed to cooperate in dealing with a delay, the delay by this failure shall not be considered in assessing the new Intended Completion Date.</p>

<b>28. Acceleration</b>	<p>28.1 When the Procuring Entity wants the Contractor to finish before the Intended Completion Date, the Project Manager will obtain priced proposals for achieving the necessary acceleration from the Contractor. If the Procuring Entity accepts these proposals, the Intended Completion Date will be adjusted accordingly and confirmed by both the Procuring Entity and the Contractor.</p> <p>28.2 If the Contractor's priced proposals for acceleration are accepted by the Procuring Entity, they shall be incorporated in the Contract Price and treated as a Variation.</p>
<b>29. Delays Ordered by the Project Manager</b>	<p>29.1 The Project Manager may instruct the Contractor to delay the start or progress of any activity within the Works.</p>
<b>30. Management Meetings</b>	<p>30.1 Either the Project Manager or the Contractor may require the other to attend a management meeting. The business of a management meeting shall be to review the plans for remaining work and to deal with matters raised in accordance with the early warning procedure.</p> <p>30.2 The Project Manager shall record the business of management meetings and provide copies of the record to those attending the meeting and to the Procuring Entity. The responsibility of the parties for actions to be taken shall be decided by the Project Manager either at the management meeting or after the management meeting and stated in writing to all who attended the meeting.</p>
<b>31. Early Warning</b>	<p>31.1 The Contractor shall warn the Project Manager at the earliest opportunity of specific likely future events or circumstances that may adversely affect the quality of the work, increase the Contract Price or delay the execution of the Works. The Project Manager may require the Contractor to provide an estimate of the expected effect of the future event or circumstance on the Contract Price and Completion Date. The estimate shall be provided by the Contractor as soon as reasonably possible.</p> <p>33.2 The Contractor shall cooperate with the Project Manager in making and considering proposals for how the effect of such an event or circumstance can be avoided or reduced by anyone involved in the work and in carrying out any resulting instruction of the Project Manager.</p>

### C. Quality Control

<b>32. Identifying Defects</b>	<p>32.1 The Project Manager shall check the Contractor's work and notify the Contractor of any Defects that are found. Such checking shall not affect the Contractor's responsibilities. The Project Manager may instruct the Contractor to search for a Defect and to uncover and test any work that the Project Manager considers may have a Defect.</p>
<b>33. Tests</b>	<p>33.1 If the Project Manager instructs the Contractor to carry out a test not specified in the Specification to check whether any work has a Defect and the test shows that it does, the Contractor shall pay for the test and any samples. If there is no Defect, the test shall be a Compensation Event.</p>
<b>34. Correction of Defects</b>	<p>34.1 The Project Manager shall give notice to the Contractor of any Defects before the end of the Defects Liability Period, which begins at Completion, and is defined in the <b>Contract Data Sheet</b>. The Defects Liability Period shall be extended for as long as Defects remain to be corrected.</p> <p>34.2 Every time notice of a Defect is given, the Contractor shall correct the notified Defect within the length of time specified by the Project Manager's notice.</p> <p>34.3 If the Contractor has not corrected a defect within the time specified in the Procuring Entity's notice, a penalty for lack of performance will be paid by the Contractor. The amount to be paid will be calculated as a percentage of the cost of having the defect correct, assessed as described in Clause 39.</p>
<b>35. Uncorrected Defects</b>	<p>35.1 If the Contractor has not corrected a Defect within the time specified in the Project Manager's notice, the Project Manager will assess the cost of having the</p>

	Defect corrected, and the Contractor will pay this amount.
--	--

### D. Cost Control

<b>36. Bill of Quantities</b>	<p>36.1 The Bill of Quantities shall contain items for the construction, installation, testing, and commissioning work to be done by the Contractor.</p> <p>36.2 The Bill of Quantities is used to calculate the Contract Price. The Contractor shall be paid for the quantity of the work done at the rate in the Bill of Quantities for each item.</p>
<b>37. Cash Flow Forecasts</b>	<p>37.1 When the Programme is updated, the Contractor shall provide the Project Manager with an updated cash flow forecast. The cash flow forecast shall include different currencies, as defined in the Contract, converted as necessary using the Contract exchange rates.</p>
<b>38. Payment Certificates</b>	<p>38.1 The Contractor shall submit to the Project Manager weekly statements of the estimated value of the work executed less the cumulative amount certified previously.</p> <p>38.2 The Project Manager shall check the Contractor's monthly statement and certify the amount to be paid to the Contractor within 7 days of receipt of the certificate from the contractor.</p> <p>38.3 The value of work executed shall be determined by the Project Manager.</p> <p>38.4 The value of work executed shall comprise the value of the quantities of the items in the Bill of Quantities completed.</p>
	<p>38.5 The value of work executed shall include the valuation of Variations and Compensation Events.</p> <p>38.6 The Project Manager may exclude any item certified in a previous certificate or reduce the proportion of any item previously certified in any certificate in the light of later information.</p> <p>38.7 The Project Manager shall not be bound to certify any payment, if the net amount, after all retentions and deductions would be less than minimum amount of Interim Payment Certificate stated in the <b>Contract Data Sheet</b>.</p>
<b>39. Payments</b>	<p>39.1 Payments shall be adjusted for deductions for advance payments and retention. The Procuring Entity shall pay the Contractor the amounts certified by the Project Manager within 7 days of the date of each certificate. If the Procuring Entity makes a late payment, the Contractor shall be paid interest on the late payment in the next payment Interest shall be calculated from the date by which the payment should have been made up to the date when the late payment is made at the prevailing rate of interest for commercial borrowing for each of the currencies in which payments are made as indicated in the <b>Contract Data Sheet</b>. If an amount certified is increased in a later certificate or as a result of an award by the Adjudicator or an Arbitrator, the Contractor shall be paid interest upon the delayed payment as set out in this clause. Interest shall be calculated from the date upon which the increased amount would have been certified in the absence of dispute.</p> <p>39.2 Unless otherwise stated, all payments and deductions will be paid or charged in the proportions of currencies comprising the Contract Price.</p> <p>39.3 Items of the Works for which no rate or price has been entered in will not be paid for by the Procuring Entity and shall be deemed covered by other rates and prices in the Contract.</p>
<b>40. Compensation Events</b>	<p>40.1 The following shall be Compensation Events:</p> <p>(a) The Procuring Entity does not give access to a part of the Site by the Site Possession Date stated in the <b>Contract Data Sheet</b>.</p> <p>(b) The Procuring Entity modifies the Schedule of Other Contractors in a way that affects the work of the Contractor under the Contract.</p> <p>(c) The Project Manager orders a delay or does not issue Drawings, Specifications, or instructions required for execution of the Works on time.</p> <p>(d) The Project Manager instructs the Contractor to uncover or to carry out additional tests upon work, which is then found to have no Defects.</p> <p>(e) The Project Manager unreasonably does not approve a subcontract to be let.</p>

	<p>(f) Ground conditions are substantially more adverse than could reasonably have been assumed before issuance of the Letter of Acceptance from the information issued to Tenderers (including the Site Investigation Reports), from information available publicly and from a visual inspection of the Site.</p> <p>(g) The Project Manager gives an instruction for dealing with an unforeseen condition, caused by the Procuring Entity, or additional work required for safety or other reasons.</p> <p>(h) Other contractors, public authorities, utilities, or the Procuring Entity does not work within the dates and other constraints stated in the Contract, and they cause delay or extra cost to the Contractor.</p> <p>(i) The advance payment is delayed.</p> <p>(j) The effects on the Contractor of any of the Procuring Entity's Risks.</p> <p>(k) The Project Manager unreasonably delays issuing a Certificate of Completion.</p> <p>(l) Other Compensation Events described in the Contract or determined by the Project Manager shall apply.</p> <p>40.2 If a Compensation Event would cause additional cost or would prevent the work being completed before the Intended Completion Date, the Contract Price shall be increased and/or the Intended Completion Date shall be extended. The Project Manager shall decide whether and by how much the Contract Price shall be increased and whether and by how much the Intended Completion Date shall be extended.</p> <p>40.3 As soon as information demonstrating the effect of each Compensation Event upon the Contractor's forecast cost has been provided by the Contractor, it shall be assessed by the Project Manager, and the Contract Price shall be adjusted accordingly. If the Contractor's forecast is deemed unreasonable, the Project Manager shall adjust the Contract Price based on the Project Manager's own forecast. The Project Manager will assume that the Contractor will react competently and promptly to the event.</p> <p>40.4 The Contractor shall not be entitled to compensation to the extent that the Procuring Entity's interests are adversely affected by the Contractor's not having given early warning or not having cooperated with the Project Manager.</p>
<b>41. Taxes</b>	41.1 The contractor shall include all payable taxes and levies in the priced BoQ.
<b>42. Currencies</b>	42.1 Where payments are made in currencies other than the Kenya Shillings, the exchange rates used for calculating the amounts to be paid shall be the exchange rates stated in the Contractor's Tender.
<b>43. Price Adjustment</b>	43.1 The Contract is not subject to price adjustment
<b>44. Liquidated Damages</b>	<p>44.1 The Contractor shall pay liquidated damages to the Procuring Entity at the rate per day stated in the <b>Contract Data Sheet</b> for each day that the Completion Date is later than the Intended Completion Date. The total amount of liquidated damages shall not exceed the amount defined in the <b>Contract Data Sheet</b>. The Procuring Entity may deduct liquidated damages from payments due to the Contractor. Payment of liquidated damages shall not affect the Contractor's liabilities.</p> <p>44.2 If the Intended Completion Date is extended after liquidated damages have been paid, the Project Manager shall correct any overpayment of liquidated damages by the Contractor by adjusting the next payment certificate. The Contractor shall be paid interest on the overpayment, calculated from the date of payment to the date of repayment, at the rates specified in Sub-Clause 46.1.</p> <p>44.3 If the Contractor has not corrected defects within the time specified in the Procuring Entity's notice, the Procuring Entity will assess the cost of having the defect corrected, the Contractor will pay this amount, and a penalty for lack of performance calculated as described in Clause 38.</p>
<b>45. Performance Securities -Will Not Be required for this Tender</b>	45.1 The Performance Security shall be provided to the Procuring Entity no later than the date specified in the Letter of Acceptance and shall be issued in an amount and form and by a bank or surety acceptable to the Procuring Entity, and denominated in the types and proportions of the currencies in which the Contract Price is payable. The Performance Security shall be valid until a date 28 days

	from the date of issue of the Certificate of Completion in the case of a Bank Guarantee, and until one year from the date of issue of the Completion Certificate in the case of a Performance Bond.
<b>46. Cost of Repairs</b>	46.1 Loss or damage to the Works or Materials to be incorporated in the Works between the Start Date and the end of the Defects Correction periods shall be remedied by the Contractor at the Contractor's cost if the loss or damage arises from the Contractor's acts or omissions.

### E. Finishing the Contract

<b>47. Completion Certificate</b>	47.1 The Contractor shall request the Project Manager to issue a certificate of Completion of the Works, and the Project Manager will do so upon deciding that the work is completed.
<b>48. Taking Over</b>	48.1 The Procuring Entity shall take over the Site and the Works within seven days of the Project Manager's issuing a certificate of Completion.
<b>49. Final Account</b>	49.1 The Contractor shall supply the Project Manager with a detailed account of the total amount that the Contractor considers payable under the Contract before the end of the Defects Liability Period. The Project Manager shall issue a Defects Liability Certificate and certify any final payment that is due to the Contractor within 56 days of receiving the Contractor's account if it is correct and complete. If it is not, the Project Manager shall issue within 56 days a schedule that states the scope of the corrections or additions that are necessary. If the Final Account is still unsatisfactory after it has been resubmitted, the Project Manager shall decide on the amount payable to the Contractor and issue a payment certificate.
<b>50. Operating and Maintenance Manuals</b>	50.1 If "as built" Drawings and/or operating and maintenance manuals are required, the Contractor shall supply them by the dates stated in the <b>Contract Data Sheet</b> . 50.2 If the Contractor does not supply the Drawings and/or manuals by the dates stated in the <b>Contract Data Sheet</b> , or they do not receive the Project Manager's approval, the Project Manager shall withhold the amount stated in the <b>Contract Data Sheet</b> from payments due to the Contractor.
<b>51. Termination</b>	51.1 The Procuring Entity or the Contractor may terminate the Contract if the other party causes a fundamental breach of the Contract. 51.2 Fundamental breaches of Contract shall include, but shall not be limited to, the following: (a) The Contractor stops work for 28 days when no stoppage of work is shown on the current Programme and the stoppage has not been authorized by the Project Manager; (b) The Project Manager instructs the Contractor to delay the progress of the Works, and the instruction is not withdrawn within 28 days; (c) The Procuring Entity or the Contractor is made bankrupt or goes into liquidation other than for a reconstruction or amalgamation; (d) A payment certified by the Project Manager is not paid by the Procuring Entity to the Contractor within 84 days of the date of the Project Manager's certificate; (e) The Project Manager gives Notice that failure to correct a particular Defect is a fundamental breach of Contract and the Contractor fails to correct it within a reasonable period of time determined by the Project Manager; (f) The Contractor does not maintain a Security, which is required; and (g) The Contractor has delayed the completion of the Works by the number of days for which the maximum amount of liquidated damages can be paid, as defined in the <b>Contract Data Sheet</b> . (h) If the Contractor, in the judgment of the Procuring Entity has engaged in corrupt or fraudulent practices in competing for or in executing the Contract. For the purpose of this paragraph: "corrupt practice" means the offering, giving, receiving or soliciting of anything of value to influence the action of a public official in the procurement process or in contract execution and includes inter alia, bribery and extortion or coercion which involves threats of injury to person, property or reputation, and. "fraudulent practice" means a misrepresentation of facts in order to influence a

	<p>procurement process or the execution of a contract to the detriment of the Procuring Entity, and includes collusive practice among Tenderers (prior to or after Tender submission) designed to establish Tender prices at artificial non-competitive levels and to deprive the Procuring Entity of the benefits of free and open competition.</p> <p>51.3 When either party to the Contract gives notice of a breach of Contract to the Project Manager for a cause other than those listed under Sub-Clause 62.2 above, the Project Manager shall decide whether the breach is fundamental or not.</p> <p>51.4 Notwithstanding the above, the Procuring Entity may terminate the Contract for convenience.</p> <p>51.5 If the Contract is terminated, the Contractor shall stop work immediately, make the Site safe and secure, and leave the Site as soon as reasonably possible.</p>
<b>52. Payment upon Termination</b>	<p>52.1 If the Contract is terminated because of a fundamental breach of Contract by the Contractor, the Project Manager shall issue a certificate for the value of the work done and Materials ordered less advance payments received up to the date of the issue of the certificate and less the percentage to apply to the value of the work not completed, as indicated in the <b>Contract Data Sheet</b>. Additional Liquidated Damages shall not apply. If the total amount due to the Procuring Entity exceeds any payment due to the Contractor, the difference shall be a debt payable to the Procuring Entity.</p>
	<p>52.2 If the Contract is terminated for the Procuring Entity's convenience or because of a fundamental breach of Contract by the Procuring Entity, the Project Manager shall issue a certificate for the value of the work done, Materials ordered, the reasonable cost of removal of Equipment, repatriation of the Contractor's personnel employed solely on the Works, and the Contractor's costs of protecting and securing the Works, and less advance payments received up to the date of the certificate.</p>
<b>53. Property</b>	<p>53.1 All Materials on the Site, Plant, Equipment, Temporary Works, and Works shall be deemed to be the property of the Procuring Entity if the Contract is terminated because of the Contractor's default.</p>
<b>54. Release from Performance</b>	<p>54.1 If the Contract is frustrated by the outbreak of war or by any other event entirely outside the control of either the Procuring Entity or the Contractor, the Project Manager shall certify that the Contract has been frustrated. The Contractor shall make the Site safe and stop work as quickly as possible after receiving this certificate and shall be paid for all work carried out before receiving it and for any work carried out afterwards to which a commitment was made.</p>
<b>55. Suspension of Financing</b>	<p>55.1 In the event that the source of financing is suspended to the Procuring Entity, from which part of the payments to the Contractor are being made:</p> <p>(a) The Procuring Entity is obligated to notify the Contractor of such suspension within 7 days of having received the financing agency's suspension notice.</p> <p>(b) If the Contractor has not received sums due it within the 28 days for payment provided for in Sub-Clause 46.1, the Contractor may immediately issue a 14-day termination notice.</p>

**SECTION V: CONTRACT DATA SHEET (CDS)**

**Contract Data Sheet**

**Instructions for completing the Contract Data Sheet**

<b>CDS Clause</b>	<b>GCC Clause</b>	<b>Description</b>
<b>1</b>	<b>1.1</b>	<p><b>A. General</b></p> <p>The Procuring Entity is <i>[Name, address, and name of authorized representative]</i>.</p> <p>The Adjudicator is <i>[Insert name]</i>.</p> <p>The Defects Liability Period is <i>[number]</i> days.</p> <p>The Project Manager is <i>[Name, address, and name of authorized representative]</i>.</p> <p>The name and identification number of the Contract is <i>[insert name and number as indicated in the Invitation for Tenders (or Pre-qualification, if any)]</i>.</p> <p>The Works consist of <i>[insert brief summary of the works, including relationship to other Contracts under the Project]</i>.</p> <p>The objectives of the contract are <i>[functional objectives of the works]</i> which are mandatory requirements that override any detail which may be provided below.</p> <p>The Start Date shall be <i>[insert date]</i>.</p> <p>The Intended Completion Date for the whole of the Works shall be <i>[insert date]</i>.</p> <p>The following documents also form part of the Contract: <i>[list documents]</i></p> <p>The Site is located at <i>[insert location]</i> and is defined in drawings No: <i>[insert numbers]</i>.</p>
<b>2.</b>	<b>2.1</b>	<p>Indicate whether there is sectional completion <i>[specified/not specified]</i>.</p> <p><i>[If there is sectional completion, insert “The sections are:</i></p> <p><i>”]</i></p>
<b>3.</b>	<b>3.1</b>	<p>List other documents that form part of the contract if any:</p> <p>a) .....</p> <p>b) .....</p> <p>c).....</p>
<b>4.</b>	<b>4.1</b>	<p>The language of the Contract documents is <i>[insert language]</i>.</p> <p>The law that applies to the Contract is the Kenyan Law.</p>
<b>5.</b>	<b>5.1</b>	<p>Include the Schedule of Other Contractors, if any.</p> <p><i>[give list of other contractors]</i></p>
<b>6.</b>	<b>6.1</b>	<p>Include the Schedule of Key Personnel.</p> <p><i>[Give list of key personnel]</i></p>
<b>7.</b>	<b>7.1</b>	<p>The minimum insurance covers shall be:</p>



		<p>(a) loss of or damage to the Works, Plant, and Materials <i>[insert amount]</i>;</p> <p>(b) loss of or damage to Equipment <i>[insert amount]</i>;</p> <p>(c) loss of or damage to property (except the Works, Plant, Materials, and Equipment) in connection with the Contract <i>[insert amount]</i>; and</p> <p>(d) personal injury or death <i>[insert amount]</i>.</p>
<b>8.</b>	<b>8.1</b>	Site Investigation Reports available to the Tenderers are: a) ..... b) ..... c).....
<b>9.</b>	<b>9.1</b>	The other measures include: a. Minimising the number of migrant workers employed on the project and household in the site camp
<b>10.</b>	<b>10.1</b>	The Site Possession Date shall be <i>[insert date]</i> .

<b>11.</b>	<b>11.1</b>	Hourly rate of Fees payable to the Adjudicator is:..... <i>[insert hourly fee in KES.]</i>  Types of reimbursable expenses to be paid to the Adjudicator include: <i>[insert types of reimbursable expenses]</i> . a) ..... b) ..... c).....
<b>12.</b>	<b>12.1</b>	Arbitration will take place at <i>[insert the place]</i> in accordance with rules and regulations published by ..... <i>[state the institutions]</i> and <i>[insert rules and regulations]</i>
<b>13.</b>	<b>13.1</b>	Appointing Authority for the Adjudicator: <i>[Insert the name of Authority]</i>

**B. Time Control**

<b>14.</b>	<b>14.1</b>	The Contractor shall Submit a Programme for the Works within <i>[number]</i> days of delivery of the Letter of Acceptance.
<b>15.</b>	<b>5.1</b>	The period between Programme updates is <i>[number]</i> days.
<b>16.</b>	<b>16.1</b>	The amount to be withheld by the Project Manager in the case the contractor does not submit an updated programme is:..... <i>[State amount]</i> .

**C. Quality Control**

<b>17.</b>	<b>17.1</b>	The Defects Liability Period is <i>[number]</i> days.
------------	-------------	---

**D. Cost Control**

<b>18.</b>	<b>18.1</b>	Minimum Amount of Interim Payment Certificate will be <i>[insert figure or percent of contract price]</i>
<b>19.</b>	<b>19.1</b>	The interest rate shall be ..... % above prevailing interest rate for commercial borrowing from the contractors' bank

20.	20.1	The Site Possession Date shall be <i>[insert date]</i> .
21.	21.1	The contract <i>[insert "is" or "is not"]</i> subject to price adjustment in accordance with Clause 50 of the General Conditions of Contract.
22.	22.1	The amount of retention is ..... <i>[state the percent]</i> of value of works of Interim Payment Certificate’.
		Limit of retention will be <i>[insert percent]</i> of contract price.
23.	23.1	The rate of liquidated damages is <i>[insert the percent]</i> <i>[Should be between 0.1 and 0.15 percent of contract price per day]</i>
		The maximum amount of liquidated damages is <i>[insert percentage]</i> <i>[should be between 5% to 10% of Contract Price]</i>
24.	24.1	The bonus for early completion is ..... <i>[state the amount]</i> .
25.	25.1	The amount of advance payment shall be ..... per cent of the contract sum payable by ..... <i>[insert date]</i> .
		Monthly Recovery of Advance Payment: ..... percent of amount of Interim Payment Certificate.
26.	26.1	The Performance Security shall be <i>[ insert percentage]</i> <i>[should be between 0 to 15 percent of the contract price].</i>
		<b>E. Finishing the Contract</b>
27.	27.1	As built drawings shall be supplied by the contractor by ..... <i>[insert date if applicable]</i> .  Operating manual shall be supplied by the contractor by ..... <i>[insert date if applicable]</i> .
28.	28.1	The amount to be withheld by the Project Manager in the case the contractor does not submit as built drawings is:..... <i>[State amount if applicable]</i> .  The amount to be withheld by the Project Manager in the case the contractor does not submit operating manual is:..... <i>[State amount if applicable]</i> .
29.	29.1	The percentage to apply to the value of the work not completed, representing the Procuring Entity's additional cost for completing the Works, is <i>[percent]</i> .

## SECTION VI: TECHNICAL SPECIFICATIONS

---

### TECHNICAL SPECIFICATIONS

#### Specifications

Wherever reference is made in the Contract to specific standards and codes to be met by the goods and materials to be furnished, and work performed or tested, the provisions of the latest current edition or revision of the relevant standards and codes in effect shall apply, unless otherwise expressly stated in the Contract. Where such standards and codes are national, or relate to a particular country or region, other authoritative standards that ensure a substantially equal or higher quality than the standards and codes specified will be accepted subject to the Project Manager's prior review and written consent. Differences between the standards specified and the proposed alternative standards shall be fully described in writing by the Contractor and submitted to the Project Manager at least 28 days prior to the date when the Contractor desires the Project Manager's consent. In the event the Project Manager determines that such proposed deviations do not ensure substantially equal or higher quality, the Contractor shall comply with the standards specified in the document Description of the works

#### Provision of equipment material and labour

The contractor shall provide all equipment, transport consumable materials and labour necessary for the satisfactory completion of the works in compliance with the specifications herein. Head of Programmes AICHM in conjunction with representative of Malteser Intaernation reserves the right to inspect plant and materials prior to contractor selection, and may reject plant or material that in his/her opinion is substandard or inappropriate. The contractor shall provide full descriptions of all plants to be deployed for these works. The contractor shall present method statements describing in detail the proposed approach to work.

The contractor shall provide summary detail of the experience of key personnel to be deployed for these works.

#### Occupation of site

The employer will provide land on which the works shall be constructed. The contractor shall be given possession of such parts of the site that he requires for activities related to construction works including storage of raw materials, equipment and setting up of camp during the period of contract provided his operation does not interfere with the daily activities of the employer.

The Contractor shall not enter upon or occupy with men, tools, equipment and materials any land other than the land or right of way provided by the employer

#### Diligent performance

The contractor shall at all times perform the Works diligently and in accordance with sound professional practice. He/she shall not proceed from one stage of works to another without the express permission of the Project Manager

Decisions regarding Temporary halt, discontinuing of any element or part of any element of these works, or abandonment of these works, shall be discussed jointly between the contractor and the Project Manager before any further actions are authorized by the Engineer. The Project Manager's decision shall be final.

The Engineer will require a written submission justifying any steps taken by the successful bidder taken without the Project Manager's approval. An unsatisfactory explanation shall lead to non-payment for works undertaken without prior agreement, and may be included for consideration as liquidated Damages.

#### Drawings

The project drawings and Attachment shall comprise.

- (a) The drawings attached to tender document

- (b) Such other drawings and/or sketches as are issued from time to time by the Project Manager to deal with design modifications in response to on-site conditions.

### **Record drawing**

As the work proceeds the Contractor shall markup 'As Built' details on a set of prints of the contract Drawings modified to portray the works as actually constructed and issue to the Project Manager for approval within 7 days of completion of the works covered by each drawing.

### **Contractor's staff, communication, offices etc.**

#### **General**

The contractor shall advise the Project Manager at which of his offices any notices may be served in accordance with the conditions of contract

### **Language of correspondence and records**

All communication from contractor to the Project Manager and the Project Manager shall be in English language.

All site books, time sheets, records, notes drawings, documents, specifications etc. shall be in English language

### **Contractor's duty staff & offices**

At least one responsible senior representative of the contractor shall be immediately available at all times and he shall be on site during normal working hours.

To such representative shall be delegated full authority to confer with Project Manager and to take all steps and to issue all those instructions which may be required in an emergency to ensure the safety of all personnel of the works and of all the Employer 's and other property on the site and in the immediate vicinity thereof. The Project Manager may from time to time at his discretion after taking into consideration all the prevailing conditions allow some relaxation of this clause but such relaxation shall be made only with his written permission and subject to any special conditions which he may then require.

The contractor shall provide and maintain at the site, offices for the use of representative and to which written instructions by the Project Manager can be delivered. Any instructions delivered to such offices shall be deemed to have been delivered to the contractor.

### **Public Relations**

The contractor shall designate within his site organization competent staff whose responsibility shall be to ensure good relations.

The location of all yards, stores, workshops, offices, etc. shall be agreed beforehand with the Project Manager and shall be such as to avoid obstruction and nuisance to public and/or the client.

The contractor shall provide and maintain at or near the site suitable and sufficient shelters, mess rooms, washrooms, latrines etc. as are necessary and customary, to the satisfaction of the Project Manager Project Manager and in accordance with the law and regulations of the relevant authorities.

### **Accommodation for workmen**

Where the contractor wishes to construct camp to accommodate his labour, the following requirements shall be adhered to and shall also be subject to the requirement made by the District or Provincial Administration or any local Authority.

### **Demolition of contractor's temporary structures**

The Project Manager may at any time before the end of the period of maintenance give the contractor notice in writing to demolish and remove those buildings and works which are no longer required, whereupon the title to such buildings and works and materials connected therewith shall revert to the contractor. After the demolition and removal of building and works as required by the Project Manager and contractor shall level, clear, restore and make good the

sites and surrounding ground and fill in and compact all latrines, drains, pits and similar works leaving the satisfaction of the Project Manager.

### **First aid outfits**

The contractors shall provide and maintain in an easily accessible place at the site of the works adequate first aid outfits for the whole duration of the contract, to the satisfaction of the Project Manager. The contractor shall have available at all times a suitable vehicle for conveyance of the sick or injured people to hospital.

### **Protective clothing**

The contractor shall provide all protective or any other special clothing or equipment for his employees that may be necessary.

### **Inspection by Project Manager during period of defects liability**

The Project Manager will give the contractor due notice of his intention to carry out any inspection during the period of Defects Liability and the contractor shall hereupon arrange for a responsible representative to be present at the times and dates named by the Project Manager. This representative shall render all necessary assistance and take note all matters and things to which his attention is directed by the Project Manager.

### **Advertisement**

No advertisements shall be placed on any boarding or scaffolding erected for any purpose connected with the contract without the written permission of the Project Manager.

### **Site investigations**

(a) Ground levels shown on the drawings are believed to be correct.

Should the contractor consider the levels shown to be inaccurate he must draw the attention of the Project Manager to the discrepancy before interfering with the existing ground.

(b) The Contractor must make such site investigations as he thinks fit and satisfy him/her as to the nature of the ground and availability of materials.

### **Work Programme**

The contractor shall submit a work program showing the sequence and timing of the various stages in the execution of the works as per the conditions of contract.

### **Facilities for the Project Manager**

The Contractor shall provide for the Project Manager or his representative:

(a) Such instruments as are necessary to enable the Project Manager to check the setting out and make such inspections as he may deem necessary.

(b) Such labour and assistance as may be required.

(c) Any facilities necessary to enable the Engineer to take samples

(d) Provide a temporary site office during the contract period.

### **Water supply**

The contractor will arrange to provide water for use in the camps and on the works. The Contractor must provide any treatment necessary to ensure it is suitable for use as in accordance to health regulations.

### **Electrical supply**

The Contractor must provide his own source of electricity if he so requires.

## **Security**

The Contractor will be responsible for the security of the Works and of site installations during the Contract period. He must provide such fencing, watching & lighting as he deems necessary.

## **Description of the materials and workmanship**

The following apply to all section's hereafter.

### **(a) Materials**

Materials, commodities, components and equipment are to be new and unused unless otherwise specified. Handle, store, fix and protect all commodities with care to ensure that they are in perfect condition when incorporated into the work and handed over on completion.

### **(b) Manufacturer's recommendation**

Handle, store and fix every commodity strictly in accordance with the printed or written recommendations of the manufacturer and/or supplier. Supply the Project Manager with copies of the manufacturer's recommendations. Inform the Project Manager if the manufacturer's recommendations conflict with any other specified requirements, and obtain his instructions before proceeding.

### **(c) Standards**

Where commodities or workmanship are specified by reference to Kenya Bureau of Standards (K.S.), or British Standards (B.S.) or Codes of Practice (C.P.) or International (I.S.O.), or other standards, such standards are deemed to be the latest published at the time of tendering. The Contractor will be deemed to have read and understood the standards specified, and no claim for want of knowledge will be allowed. The substitution of commodities or standards of workmanship complying with other standards may be allowed at the discretion of the Project Manager, but application for permission for such substitution must be made in writing in sufficient time to allow adequate investigation. Obtain Certificates of Compliance with standards and supply to the Project Manager on request.

### **(d) Local conditions**

All materials, commodities, components and equipment must be suitable for use in hot climates.

## **Samples**

The Contractor shall submit to the Project Manager samples of materials to be used in the works, the samples must be fairly representative of the bulk to be supplied. Samples should be subject to relevant tests before submission and Test Certificates should accompany the samples.

## **Clearing site on completion**

The site, including borrow pits and spoil dumps shall be carefully tidied up on completion, and shaped to avoid ponding, holes, and dangerous slopes. The borrow pits and spoil dumps must be covered with topsoil neatly trimmed and the whole site left in a tidy and satisfactory condition.

## **EARTHWORKS**

### **Clearing in general**

Clear the area of the permanent works, and borrow pits of all vegetation and destroy by burning or otherwise.

### **Stripping top soil**

N/A

### **Excavation and classification**

Excavation shall be carried out to the lines and levels shown on the drawings or to such other lines and levels as the Engineer may direct.

Excavation in excess of the lines and levels shown on the drawings or without the approval of the Engineer will be rectified by the Contractor at his expense in a manner approved by the Engineer.

Any patches of unsuitable ground in the bottom of the excavations shall be excavated to such additional depth as the Engineer may direct.

Excavated material shall be taken to embankment fill or to spoil tip as the Engineer may direct.

Excavation must be kept dry and the sides supported as necessary. Excavation classification shall be as in the Ministry of Works Standard Specification (MOWSS) Section 5.

**Class 1 "Rock" or "Hard Material"** shall include all materials which in the opinion of the Project Manager requires blasting or the use of metal wedges or the use of compressed air drilling for its removal or cannot be extracted by ripping with a tractor of less than 180 hp. and rear mounted heavy ripper. Individual boulders greater than 0.2 m<sup>3</sup> in volume shall be included in this class when their nature and size are such that they cannot be removed without recourse to one of these methods.

When a portion of excavation contains 75% or more by volume of boulders of this order such portion shall be considered as class 1 material throughout.

**Class 2 "Normal" or "Soft Material"** shall include all material, which, in the opinion of the Engineer, does not require blasting and metal wedges and sledge hammers, or compressed air drilling or rooting or ripping.

It shall include wearing course gravel stones and boulders less than 0.2 m<sup>3</sup> in volume that can be removed without recourse to these methods.

**Class 3 "Compacted Gravel" or "Decomposed Rock"** shall include all material such as consolidated murrum and decomposed stratified rock, stones or boulders less than 0.2 m<sup>3</sup> in volume which are harder than "soft" or "normal" material in that they may be extracted by ripping as defined in Class 1, or in confined spaces by hand excavation using compressor tools, provided all other reasonable steps to the satisfaction of the Project Manager have been taken to facilitate the removal by other methods.

**"Waterlogged Material" material (Class 2 and Class 3)** that is excavated in a waterlogged condition and necessitates de-watering and pumping operations, provided all reasonable precautions have been taken by the contractor to dewater the material to the satisfaction of the Project Manager.

### **Blasting**

The prior approval of the Project Manager must be obtained and the methods approved if the Contractor wishes to remove rock by Blasting. The handling and use of explosives must comply with the explosives act or the department of mines and geology regulations. All necessary precautions to prevent injury or Damage to person or property must be taken. Generally blasting on the Weir site is to be avoided.

### **Borrow areas**

N/A

### **Spoil tips**

Surplus or unsuitable materials are to be disposed of in spoil tips to be approved by the Project Manager. Spoil tips must be neatly graded, properly drained, and have stable slopes and a tidy appearance.

### **Earth-fill**

The embankment is to be built of selected soil as specified and shown on the drawings. The earth-fill shall be of cohesive material of low permeability, with negligible organic matter. Specially selected material free from stones shall be used in the cut off and central zone; the upstream zone shall also be free of stones; the downstream zone may have small quantities of stone not exceeding 25 mm.

**Compaction of earth-fill**

Earth fill shall be placed and mechanically compacted in layers, approximately horizontal, to give a finished thickness of not more than 150 mm after compaction to 95% of Proctor Maximum Dry Density. Each layer shall be scarified to ensure a satisfactory bond with the next overlying layer, and water shall be added if necessary to ensure uniform moisture content. Subsequent layers will be placed only after the previous layer has been ratified by the Project Manager.

Heavy rollers of a type and weight to be approved by the Project Manager shall be used for compaction. In the cut off trench and other confined spaces compaction in area which the rollers cannot serve shall be by means of approved pneumatic tampers.

**TANKS, SUPPORT STRUCTURES AND ANCILLARIES' REGULATIONS AND STANDARDS**

The complete work shall be carried out as per the specifications and complying with the following regulations and standards:

- a) World health Organization Safety Regulations and Standards
- b) Kenya Bureau of Standards



## **SECTION VII: DRAWINGS**

*Attached at annex*

## **SECTION VIII: BILL OF QUANTITIES**

<b>BILL OF QUANTITY FOR IMPROVEMENT WORKS AT LOPUR DISPENSARY IN TURKANA COUNTY</b>					
	<p><i><b>Notes:</b> The contractor is reminded to visit the site before filling the respective rates in the bills of quantities and to ascertain the extent of the conditions of site. Additionally, the contractor is also encouraged to carefully look at the drawings, elements descriptions and the technical specifications that are attached to this bill of quantities to be aware of scope of works and the quality work that is required. All quantified works in the tender are provisional and payment shall be made based on the actual work executed at the site and agreed upon by all parties. The contractor is advised to constantly seek the AIC-HM Engineer instructions at each phase of the work and if required, before filling the tender. In case any discrepancy is noted between drawings and BoQ/units of measurements or any other technical specifications, the contractor is instructed to raise such concerns before closure of tender. Additionally, if the contractor deems that any part of relevant works are not captured or not properly captured in the bills of quantity, such a concern should be raised before close of tender. All unit rates shall be deemed to include all elements of supplying and construction work that is labour and other overheads eg security, profit and overheads, cost of materials, wastages, transport etc. AIC-HM will not pay for any contractor cess or any county related payments to facilitate movement of materials and the provided unit rates should be inclusive of such whenever deemed relevant.</i></p> <p><i>The contractor shall provide, erect and maintain all safety measures requirements according to specifications, including protecting the scaffolding with special cloth or fabric, and work plan for all items should be submitted before starting any activity.</i></p>				
#	Descriptions	Units	Qty	Rate(Ksh)	Total(Kshs)
	CONTAINER OFFICE WITH A ROOF COVER AND EXTENDED VERANDAH				
	<u>ELEMENT NO.1</u>				

	<b><u>SUB-STRUCTURES WORKS-(PROVISIONAL)</u></b>				
	-				
	<b><u>All works in this section are measured upto and including the ground stub column bases of container.</u></b>				
	-				
	<b><u>Mobilization:</u></b>				
A	Mobilize the manpower and materials to the site and arrange/set up for the material storage, and any other necessity ready to take up the site for the works	ITEM	1		
B	Mobilize 40 feet container to Site in preparation for all the works to be undertaken to the container at Lopur Dispensary	ITEM	1		
C	Excavation				
	Clear the area of construction from bushes, and trim the trees roots, twigs and any other waste from the site.	SM	47		
D	Clean the area of work from all the waste and debris from other buildings and cart away from site.	ITEM	1		

E	Excavate in black cotton soil not exceeding 1.5M deep starting from ground level for the container stub column bases.	CM	3		
F	Ditto but for the verandah steel column posts holes	CM	1		
G	Allow for upholding sides of excavations.	ITEM	1		
H	Allow for keeping all excavations free from general water.	ITEM	1		
I	Cart away surplus excavated material to own spoil heaps.	CM	1		
J	Level and compact bottoms of excavated column bases as directed on site.	SM	2		
K	Class 15/20 strength, concrete mix 1:3:6 in:-Stub column bases blinding	SM	2		
L	Class 25/20 strength, vibrated concrete mix 1:1.5:3 in:-Stub columns and verandah	CM	4		

M	Ditto but to the verandah roof posts.	CM	1		
N	Ditto but to the verandah walk way(100mm thick).	CM	2		
	<b>High tensile steel reinforcement bars</b>				
	Supply and fix steel bars in foundation steel work including cutting, bending, hoisting, and tying wire and supporting all in position as per the structural drawings following BS 8666: 2020 version and details as follows for column base of the container.				
O	Column bases and column section below OGL using T12 bars as per the structural drawings and details	Kg	280		
P	Ditto for column section below OGL but using T8 stirrups	Kg	90		
	<b><u>Form work</u></b>				
Q	Sawn formwork to edge of concrete columns well secured in place and supported to ensure it cant give in	SM	20		
	<b><u>Plinths</u></b>				
R	12mm Thick cement sand (1:4) rendering to stub columns.	SM	8		
S	Apply two coats of bituminous paint to rendered plinths.	SM	16		
	<b><u>Grand Sub total</u></b>				
	<b><u>COLLECTION</u></b>				
	-				

	Brought forward from page page 1					-
	<b><u>Grand Sub total</u></b>					-
<b>#</b>	<b>Descriptions</b>	<b>Units</b>	<b>Qty</b>	<b>Rate(Ksh)</b>	<b>Total(Kshs)</b>	
	<b><u>ELEMENT NO.2</u></b>					
	<b><u>SUPER-STRUCTURE WORKS:</u></b>					
	<b><u>STEEL CONTAINERS (12M LONG (40 FEET)</u></b>					
	<b><u>Transportation and hoisting in position (on column bases)</u></b>					
A	Transport and hoist to the prepared column bases and ensure all the containers edges are placed at the centre of the bases	ITEM	1			
	<b><u>Steel container opening slots cutting</u></b>					
B	Measure, mark and cut into size the window & door openings as per provided drawing and ensure the window will fit into the slots to be cut Window size (1810mm Lx1200mmH)	ITEM	4			

C	Standard section purpose made galvanized steel casement window; coated red oxide primer before fixing; including fixing lugs, cutting and pinning to concrete or blockwork; complete with all necessary ironmongery for 1810*1200 (width and height) windows, with two sides hang light; one fixed bottom light and one fixed light. Rate inclusive of window strainers.	NO	2		
D	Ditto but for the Steel door (size 900x2100mm)	NO	2		
E	6mm clear glass fixed to windows with putty	SM	8		
F	Ditto but for the doors	SM	3		
<b><u>Steel container internal lining with Block boards.</u></b>					
<i>Provide and fix in position Block board lining materials to the internal walls of the container measured in;</i>					
<b><u>NOTE: Provide the boards support mechanism</u></b>					
G	Walls of container(25mm thick)	SM	103		

H	Gypsum ceiling complete with chanel, screws and accessories gyproc filler etc as HADA or approved equivalent and undercoat	SM	43		
	<b>Floor Finishes</b>				
	50mm Thick cement sand (1:3) screed wood floated to receive tiles floor finish.	SM	45		
I	400x400mmx7.4mm coloured floor tiles fixed with and including cement adhesive (non-slip ceramic tiles)	SM	45		
	Supply and fix 100mm high skirting tiles for all the rooms	SM	10		
	<b><u>Grand Sub total carried to collections</u></b>				<u><u>-</u></u>
<b>#</b>	<b>Descriptions</b>	<b>Units</b>	<b>Qty</b>	<b>Rate(Ksh)</b>	<b>Total(Kshs)</b>
	<b><u>ELEMENT NO.3.</u></b>				
	<b>ROOF WORKS:(SHS Steel Tubes and iron sheets)</b>				



A	Steel roof made of rafters and purlins of the size 40x40mmX2mm, and 50x50mm anchored on the container and the roof cover made of gauge 28 GI sheets all as measured on; 28 gauge GI sheet laid with a minimum of 200mm on slope and 100mm minimum on end lap. Iron sheets are fixed on the purlins with the help of steel screws (Measured net-Allow for the overlap)	M2	115		
B					
	Roof steel Trussed Rafter size 50x50mmX3mm welded and supported on the container detailed on designs.	LM	100		
C	Straight SHS steel purlin size 40x40mm welded on the roof rafter straight to the set lines along the rafter slope.	LM	126		
D	S.H.S 50x50x3mm thick Verandah Posts(3.3M post)	LM	12		
E	Ridge cap of the same colour and quality of iron sheets	LM	13		
F	MS Plate 1.5mm Fascia board size 200mm wide	LM	63		
	<b>Painting Finishes</b>				

G	Prepare and apply 3 coats softwhite vinyl silk emulsion 'duracoat' paint to walls	SM	103		
H	Prepare and apply 3 coats brilliant white vinyl silk emulsion as 'duracoat' brand paint to ceiling	SM	43		
	Scrub clean the external surfaces of the container and				
I	apply one coat of oil paint primer and two finishing coats				
	of the IOM colour oil paint. Preferable Basco/Duracoat paint.	SM	180		
J	General painting of the steel with one coat of oil paint and				
	as undercoat and two finish coats of oil paint to AIC-HM engineer				
	paint colour preference.	ITEM	1		
K	Supply and fix Steel frame of length 0.4M and heigh 0.4M high				
	shelves made of S.H.S 25X25X2mm as columns and 25mm				
	Ms angle line with 20mm Mdf boards as base of shelves	ITEM	1		
	The shelves should be painted with Oil gloss paint and should be				

	Portable and be able to be located for both the rooms				
L	Provide and install steel gutter together with down pipes including all connections to drain water from the roof gutter size to be 200x240mm	LM	40		
	<b>Grand Sub total carried to collections</b>				-
<b>#</b>	<b>Descriptions</b>	<b>Units</b>	<b>Qty</b>	<b>Rate(Ksh)</b>	<b>Total(Kshs)</b>
	<b><u>ELEMENT NO.4:ELECTRICAL WORKS</u></b>				
	<b><u>Container Power installation</u></b>				
					-
	<i>Twin Power Socket Points Wiring:</i>				
	Wiring of power outlet socket points with PVC insulated copper conductor single core of size 3x2.5 sqmm and in 2.0mm thick, 25mm dia PVC conduits including Bends, Tee, Junctions etc in container walls lining.or <b>Single cable of 3 cores equal approved</b>	LM	90		

	<b><i>Twin Switch Points Wiring:</i></b>				
B	Wiring of power outlet switches points with PVC insulated copper				
	conductor single core of size 3x1.5 sqmm and in 2.0mm thick,				
	25mm dia PVC conduits including Bends, Tee, Junctions etc in	LM	50		
	container walls lining.or <b>single cable of 3 cores equal approved</b>				
	<b><i>Internal light Points wiring:</i></b>				
C	Lighting points wired in 1.5mm <sup>2</sup> TWE pvc sc copper cables drawn in				
	20mm dia. PVC H.G. conduits or plainly laid and concealed by the.				
	lining of the container. <b>or single cable of 3 cores equal approved</b>	LM	90		
D	20mm dia. pvc heavy gauge conduits.	LM	150		
	<b><i>Consumer unit:</i></b>				
E	6 Way recessed consumer unit complete with 63A DP intergral				

	isolator with front cover ABB OR EQUAL AND APPROVED. And				
	with 10Amps,20amps,and 32Amps isolators for other internal connectors	NO	1		
	<i>Lights, Sockets and switches fixtures</i>				
F	LED fluorescent Lights of 18watts-4ft complete with its holder	NO	4		
G	13A twin switched socket-outlet as MK OR EQUAL AND APPROVED	NO	12		
H	45A DP switch as MK OR EQUAL AND APPROVED	NO	3		
I	2 gang 2 way switch as MK OR EQUAL AND APPROVED recessed				
	in lining walls.	NO	3		
J					
	Feeding cable to the consumer unit from a 4 core x 6 sq mm Armoured PVC/SWA/PVC cable from compound DB to new CUs.	LM	40		
K	Clearance and Landscaping	LS	1		

<b>AIR CONDITIONERS</b>					
	<b>Supply, fix and commission air conditioning units of Sumsung, Daikin, LG, Hisense or equivalent and approved split air conditioning units.</b>				
L	a)Complete unit of 12000 BTUs per hour, with EER 2-3, Cooling capacity 3,000-3450W low noise level and UTR Compressor, minimum warranty 5 years plus as described and shown on drawings. Include required accessories and fittings, mounting should be at least 600mm off the ground. The air conditioner should come with ozone friendly gas as A410, R22 or other EPRA approved gas. The AC item is inclusive of AC sockets	NO	2		
M	b)Blanked power outlet points for Air Conditioning units comprising single boxes wired in 3 x 4mm sq SC-PVC-Cu cables including wiring for both outdoor & indoor units	NO	2		
	<b>CONSTRUCTION OF WAITING SHED (6mx5m) SPACE AT LOPUR DISPENSARY</b>				
N	Clear the site to remove trees and top soil to an average depth of 200mm. The work includes mobilization, site clearing the scrubs, removal any tree and roots.	SM	35		
O	Excavate for Holes 300x300x900 mm deep to Receive columns SHS Column	No	6		
	stands ffor the waiting shade				

P	Supply and fix SHS 50X50X3mm, 3.0m Long; Each welded to 4No 200mm long 50x50x3mm thick AHS pieces at the bottom for anchorage with the column base concrete and a 4.0mm thick, 150mm wide plate at the top for welding of steel truss (measured separately). Posts to be painted with two coats Red Oxide and two coats of approved gross paint before casting.	LM	36		
Q	Build external in-situ concrete slab Concrete mix 1:1.5:3 trowel finished smooth for the floor section concrete, gradient 1:20 width mm 1200, as per the drawings and specifications. Rate to include pattern grooves and red oxide painting.	SM	35		
<b>ELEMENT No. 3: ROOFING</b>					
<b>Cover</b>					
R	Supply and fix Gauge 28, IT5 sheets (blue colour) laid and tapping screwed on steel purlins on to the 3No.trusses and rafters, fixed with roof self tapping screws with washers and caps	SM	35.0		
	Supply and fix fabricated steel trusses; in 3No. Trusses spanning 6.0m and hoisted at a height n.e. 3.0m from the floor level; as described. Price to include transportation, hoisting, welding and 2 coat crown gloss oil painting, all as necessary.				
S	50x50x3mm SHS Tie beam	LM	24		
T	50x50x3mm SHS Rafters	LM	18		
U	50x25x3mm RHS struts and ties	LM	12		
V	40x40x3mm SHS purlins	LM	30		

W	225 x 25mmX2mm metal plate fascia board or barge board with rate inclusive of undercoat paint and 2 coats of gloss oil paint	LM	30		
	<b>ELEMENT NO. 4: BENCHES</b>				
X	Supply and fix SHS of 25x25x1.5mm sections (1.12Kg/m)and Ms sheet for use in making seats/ benches in the waiting shades. Rate to include painting works. The benches shall be 250mm Wide round , with access path.	Item	1		
	<b>Paintworks</b>				
Y	Touch-up, prime and prepare and apply 2 coats of undercoat and 1 coat of gloss paint finish; as 'CROWN' paints or other equal and approved;	Item	1		
	<b>Grand Sub total carried to collections</b>			-	_____ -
<b>#</b>	<b>Descriptions</b>	<b>Units</b>	<b>Qty</b>	<b>Rate(Ksh)</b>	<b>Total(Kshs)</b>
					-
	<b><u>SUMMARY COLLECTION</u></b>				
			-		
	Brought forward from page 2	Job	1	-	-





**SECTION IX: TENDER FORMS**  
**A. Form of Tender**

(On letterhead of the tenderer)

[Date]  
TENDER NAME:  
TENDER NO:  
Dear Sir,

1. In accordance with the Conditions of Contract, Specifications, Drawings and Bills of Quantities for the execution of the above named Works, we, the undersigned offer to construct, install, complete and maintain the whole of the said works and remedy any defects therein for the sum of Kshs.....  
[Amount in figures].....  
Kenya Shillings [Amount in words]

2. We undertake, if our tender is accepted, to commence the Works as soon as is reasonably possible after the receipt of the Engineer's notice to commence, and to complete the whole of the Works comprised in the Contract within the time stated in the Appendix to Conditions of Contract.

3. We agree to abide by this tender until ..... [Insert date], and it shall remain binding upon us and may be accepted at any time before that date.

4. Unless and until a formal Agreement is prepared and executed this tender together with your written acceptance thereof, shall constitute a binding Contract between us.

5. We understand that you are not bound to accept the lowest or any tender you may receive.

Dated this \_\_\_\_\_ day of \_\_\_\_\_ 20\_\_\_\_\_

Signature \_\_\_\_\_ in the capacity of \_\_\_\_\_

duly authorized to sign tenders for and on behalf of \_\_\_\_\_  
[Name of Tenderer]

of \_\_\_\_\_ [Address of Tenderer]

Witness; Name \_\_\_\_\_

Address \_\_\_\_\_

Signature \_\_\_\_\_

Date \_\_\_\_\_

**BID FORM**

THE EXECUTIVE DIRECTOR  
AIC HEALTH MINISTRIES  
P. O. BOX 40431-00100  
NAIROBI

**Dear Sir,**

**BID FOR: FABRICATION, SUPPLY AND INSTALLATION OF 40FT CONTAINERS, TURKANA COUNTY.**

Having examined the bid documents, specifications, drawing, schedules and Bills of Quantities for the works described in these documents, we the undersigned offer to carry out all the works in conformity with this Contract for the sum of

**Kshs:**.....  
.....(Amount in words) **Kshs:**.....(Amount in figures).

We undertake if our bid is accepted to commence the works as soon as it is reasonably possible after receipt of the Client's Order to commence and to complete and deliver the whole of the works comprised in the Contract within.....(days) from the Commencement date.

We agree to abide by this Bid for the Bid validity period of one hundred and twenty (140) days, from the tender opening date and it shall remain binding upon us and may be accepted at any time before the expiration of that period.

We also agree that pending the preparation and execution of the formal Agreement, this Bid together with the notification of award of the contract shall constitute a binding contract between the Client and the Contractor.

Dated this .....day of ..... 2024.

		Witness
Signature	.....	.....
Name	.....	.....
In the Capacity of	.....	.....
	.....	.....

## B. Tender-Securing Declaration

Date:

Tender No.:

To: *[insert complete name of Procuring Entity]*

We, the undersigned, declare that:

We understand that, according to your conditions, Tenders must be supported by a Tender-Securing Declaration.

We accept that we will automatically be suspended from being eligible for Tendering in any contract with the Procuring Entity for the period of time of 2 YEARS starting on 27<sup>th</sup> December 2024 if we are in breach of our obligation(s) under the Tender conditions, because we;

- a) Have withdrawn our Tender during the period of Tender validity specified in the Form of Tender; or
- b) Having been notified of the acceptance of our Tender by the Procuring Entity during the period of Tender validity,
  - (i). Fail or refuse to execute the Contract, if required, or
  - (ii). Fail or refuse to furnish the Performance Security, in accordance with the ITT.

We understand this Tender Securing Declaration shall expire if we are not the successful Tenderer, upon the earlier of;

- 1) Our receipt of your notification to us of the name of the successful Tenderer; or
- 2) Thirty days after the expiration of our Tender.

Signed: *[insert signature of person whose name and capacity are shown]* In the capacity of *[insert legal capacity of person signing the Tender Securing Declaration]*

Name: *[insert complete name of person signing the Tender Securing Declaration]*

Duly authorized to sign the Tender for and on behalf of: *[insert complete name of Tenderer]*

Dated on \_\_\_\_\_ day of \_\_\_\_\_, \_\_\_\_\_ *[insert date of signing]*

Corporate Seal (where appropriate)

### C. Confidential Business Questionnaire

ITEM	DESCRIPTION
1	Name of the Procuring Entity
2	Reference Number of the Tender
3	Date of Submission
4	Name of the Tenderer
5	Full Address and Contact Details of the Tenderer. <ol style="list-style-type: none"> <li>1. Country</li> <li>2. City</li> <li>3. Location</li> <li>4. Building</li> <li>5. Floor</li> <li>6. Postal Address</li> <li>7. Name and email of contact person.</li> </ol>
6	Current Trade License Registration Number and Expiring date
7	Name, country and full address ( <i>postal and physical addresses, email, and telephone number</i> ) of Registering Body/Agency
8	Description of Nature of Business
9	Maximum value of business which the Tenderer handles.
10	State if Tenders Company is listed in stock exchange, give name and full address ( <i>postal and physical addresses, email, and telephone number</i> ) of state which stock exchange

**General and Specific Details**

b) **Sole Proprietor**, provide the following details.

Name in full \_\_\_\_\_ Age \_\_\_\_\_ Nationality \_\_\_\_\_  
\_\_\_\_\_ Country of Origin \_\_\_\_\_ Citizenship \_\_\_\_\_  
\_\_\_\_\_

c) **Partnership**, provide the following details.

	<b>Names of Partners</b>	<b>Nationality</b>	<b>Citizenship</b>	<b>% Shares owned</b>
1				
2				
3				

d) **Registered Company**, provide the following details.

i) Private or public Company \_\_\_\_\_

ii) State the nominal and issued capital of the Company \_\_\_\_\_

Nominal Kenya Shillings (Equivalent)..... Issued

Kenya Shillings (Equivalent).....

iii) Give details of Directors as follows.

	<b>Names of Director</b>	<b>Nationality</b>	<b>Citizenship</b>	<b>% Shares owned</b>
1				
2				
3				

(e) **DISCLOSURE OF INTEREST- Interest of the Firm in the Procuring Entity.**

i) Are there any person/persons in ..... (*Name of Procuring Entity*)  
who has/have an interest or relationship in this firm? Yes/No.....

If yes, provide details as follows.

	<b>Names of Person</b>	<b>Designation in the Procuring Entity</b>	<b>Interest or Relationship with Tenderer</b>
1			
2			
3			

ii) Conflict of interest disclosure

	Type of Conflict	Disclosure YES OR NO	If YES provide details of the relationship with Tenderer
1	Tenderer is directly or indirectly controls, is controlled by or is under common control with another tenderer.		
2	Tenderer receives or has received any direct or indirect subsidy from another tenderer.		
3	Tenderer has the same legal representative as another tenderer		
4	Tender has a relationship with another tenderer, directly or through common third parties, that puts it in a position to influence the tender of another tenderer, or influence the decisions of the Procuring Entity regarding this tendering		

	Type of Conflict	Disclosure YES OR NO	If YES provide details of the relationship with Tenderer
	process.		
5	Any of the Tenderer's affiliates participated as a consultant in the preparation of the design or technical specifications of the works that are the subject of the tender.		
6	Tenderer would be providing goods, works, non-consulting services or consulting services during implementation of the contract specified in this Tender Document.		
7	Tenderer has a close business or family relationship with a professional staff of the Procuring Entity who are directly or indirectly involved in the preparation of the Tender document or specifications of the Contract, and/or the Tender evaluation process of such contract.		
8	Tenderer has a close business or family relationship with a professional staff of the Procuring Entity who would be involved in the implementation or supervision of such Contract.		
9	Has the conflict stemming from such relationship stated in item 7 and 8 above been resolved in a manner acceptable to the Procuring Entity throughout the tendering process and execution of the Contract.		

**f) Certification**

On behalf of the Tenderer, I certify that the information given above is complete, current and accurate as at the date of submission.

Full Name

Title or

Designation \_\_\_\_\_

\_\_\_\_\_  
*(Signature)*

\_\_\_\_\_  
*(Date)*



## **Integrity Declaration**

### **UNDERTAKING BY TENDERER ON ANTI – BRIBERY POLICY / CODE OF CONDUCT AND COMPLIANCE PROGRAMME**

1. Each Tenderer must submit a statement, as part of the Tender documents, in either of the two given formats which must be signed personally by the Chief Executive Officer or other appropriate senior corporate officer of the Tendering company and, where relevant, of its subsidiary in the Kenya. If a Tender is submitted by a subsidiary, a statement to this effect will also be required of the parent company, signed by its Chief Executive Officer or other appropriate senior corporate officer.
2. Tenderers will also be required to submit similar No-bribery commitments from their subcontractors and consortium partners; the Tenderer may cover the subcontractors and consortium partners in its own statement, provided the Tenderer assumes full responsibility.
3.
  - a) Payment to agents and other third parties shall be limited to appropriate compensation for legitimate services.
  - b) Each Tenderer will make full disclosure in the Tender documentation of the beneficiaries and amounts of all payments made, or intended to be made, to agents or other third parties (including political parties or electoral candidates) relating to the Tender and, if successful, the implementation of the contract.
  - c) The successful Tenderer will also make full disclosure [quarterly or semi-annually] of all payments to agents and other third parties during the execution of the contract.
  - d) Within six months of the completion of the performance of the contract, the successful Tenderer will formally certify that no bribes or other illicit commissions have been paid. The final accounting shall include brief details of the goods and services provided that they are sufficient to establish the legitimacy of the payments made.
  - e) Statements required according to subparagraphs (b) and (d) of this paragraph will have to be certified by the company's Chief Executive Officer, or other appropriate senior corporate officer.
4. Tenders which do not conform to these requirements shall not be considered.
5. If the successful Tenderer fails to comply with its No-bribery commitment, significant sanctions will apply. The sanctions may include all or any of the following:
  - a) Cancellation of the contract;
  - b) Liability for damages to the public authority and/or the unsuccessful competitors in the Tendering possibly in the form of a lump sum representing a pre-set percentage of the contract value (liquidated).
6. Tenderers shall make available, as part of their Tender, copies of their anti-Bribery Policy/Code of Conduct, if any, and of their-general or project - specific - Compliance Program.

**ANTI-CORRUPTION DECLARATION COMMITMENT/ PLEDGE**

I/We/Messrs.....

of Street, Building, P O Box.....

.....

Contact/Phone/E mail.....

declare that Public Procurement is based on a free and fair competitive Tendering process which should not be open to abuse.

I/We.....

declare that I/We will not offer or facilitate, directly or indirectly, any inducement or reward to any public officer, their relations or business associates, in connection with

Tender/Tender No .....

for or in the subsequent performance of the contract if I/We am/are successful.

Authorized Signature.....

Name and Title of Signatory.....

## DECLARATION OF SUPPLIERS

We \_\_\_\_\_ [company name] herewith declare that

- a) We do respect basic social rights and working conditions based on international labour standards and condemn the exploitation of child labour;
- b) We are not bankrupt or being wound up, are not having our affairs administered by the courts, have not entered into an arrangement with creditors, have not suspended business activities, are not the subject of proceedings concerning those matters, and are not in any analogous situation arising from a similar procedure provided for in national legislation or regulations;
- c) We have not been convicted of an offence concerning our professional conduct by a judgment which has the force of res judicata;
- d) We have not been guilty of grave professional misconduct;
- e) We have fulfilled all obligations relating to the payment of social security contributions or the payment of taxes in accordance with the legal provisions of the country in which we are established or with Kenya or those of the country where the contract is to be performed;
- f) We have not been the subject of a judgment which has the force of res judicata for fraud, corruption, involvement in a criminal organisation or any other illegal activity detrimental to AIC Health Ministries' financial interests;
- g) Following another procurement procedure carried out by AIC Health Ministries or another contracting authority, we have not been declared to be in serious breach of contract for failure to comply with our contractual obligations;
- h) We are not subject to a conflict of interest with regard to this tender. We declare that the price on the bid attached is a market competitive offer from my organization, and we are submitting to this procurement process without any conflict of interest, or the provision / receipt of any commission, gift, bribe, gratuity or remuneration of any kind.
- I) We are not guilty of misrepresentation in supplying the information required by AIC Health Ministries as a condition of participation in the contract procedure.
- j) We do not perform any act or omit to perform any act, including any misrepresentation, in order to knowingly mislead, or attempt to knowingly mislead AIC HEALTH MINISTRIES and/or any other party to obtain a financial or other benefit or to avoid any obligation ("Fraudulent Practice");
- k) We do not offer, give, receive or solicit, directly or indirectly, or attempt to offer, give, receive or solicit, directly or indirectly, anything of value to improperly influence the actions of AIC HEALTH MINISTRIES and/or any other party ("Corrupt Practice");
- l) We do not enter into any arrangements with any other party or parties that are designed to achieve an improper purpose, including but not limited to improperly influencing the actions of AIC HEALTH MINISTRIES and/or any other party or engaging in price fixing ("Collusive Practice", and together with "Fraudulent Practices and Corrupt Practices", "Prohibited Practices").
- m) We do not engage in transactions with, or provide resources or support to, individuals and organizations associated with terrorism, whether in cash or in kind, directly or indirectly.
- n) We verify that no support or resources are provided to individuals or entities associated with terrorism as designated on the „Consolidated list of persons, groups and entities subject to EU financial sanctions” maintained by the European Commission or by any other similar sanction list of individuals and entities that may be established by the United Nations Security Council or the United States of America.
- o) We do not engage in acts that directly support or advance trafficking in persons, including the following acts:

- i Destroying, concealing, confiscating, or otherwise denying an employee access to that employee’s identity or immigration documents;
  - ii. Failing to provide return transportation or pay for return transportation costs to an employee from a country to the country from which the employee was recruited upon the end of employment if requested by the employee.
  - iii. Soliciting a person for the purpose of employment, or offering employment, by means of materially false or fraudulent pretences, representations, or promises regarding that employment.
- p) We do respect applicable law relating to anti-money laundering in the execution of our contracts.

**General statements:**

- 1.1 The contractor shall communicate these fundamentals of AIC HEALTH MINISTRIES’s Policy to its management, employees, subcontractors and agents and shall take all reasonable measures to ensure that such persons do not engage in prohibited practices.
- 1.2 The contractor shall immediately disclose to AIC HEALTH MINISTRIES any actual, apparent, potential or attempted prohibited practice that the contractor becomes aware of. To that end, the contractor shall fully cooperate, and shall take all reasonable steps to ensure that its management, employees, subcontractors and agents fully cooperate with any investigation of prohibited practices by AIC HEALTH MINISTRIES, including by complying with all reasonable requests from AIC HEALTH MINISTRIES to gain access to and inspect any records, documents and other relevant information.
- 1.3 AIC HEALTH MINISTRIES is committed to the protection of vulnerable populations in humanitarian crisis, including from sexual exploitation and abuse. By entering into a contract with AIC HEALTH MINISTRIES, the contractor undertakes to ensure that its personnel, agents and subcontractors conform to the highest standards of moral and ethical conduct.

The contractor expressly acknowledges and agrees that:

- a) Any breach of this policy by the contractor or by any of its management, employees, subcontractors or agents constitutes a material breach of the contracts, which entitles AIC HEALTH MINISTRIES to immediately terminate a contract without incurring any liability to the contractor; and
- b) In the event that AIC HEALTH MINISTRIES were to determine through an investigation or otherwise that a prohibited practice occurred, AIC HEALTH MINISTRIES shall have, in addition to its right to immediately terminate the contract, the rights to:
  - i. Apply and enforce the relevant sanctions in accordance with its internal regulations, rules, procedures, practices, policies and guidelines, including referral of the matter to national authorities when appropriate; and
  - ii. Recover all losses, financial or otherwise, suffered by AIC HEALTH MINISTRIES in connection with such prohibited practices.

---

Date & Signature

---

Name of company

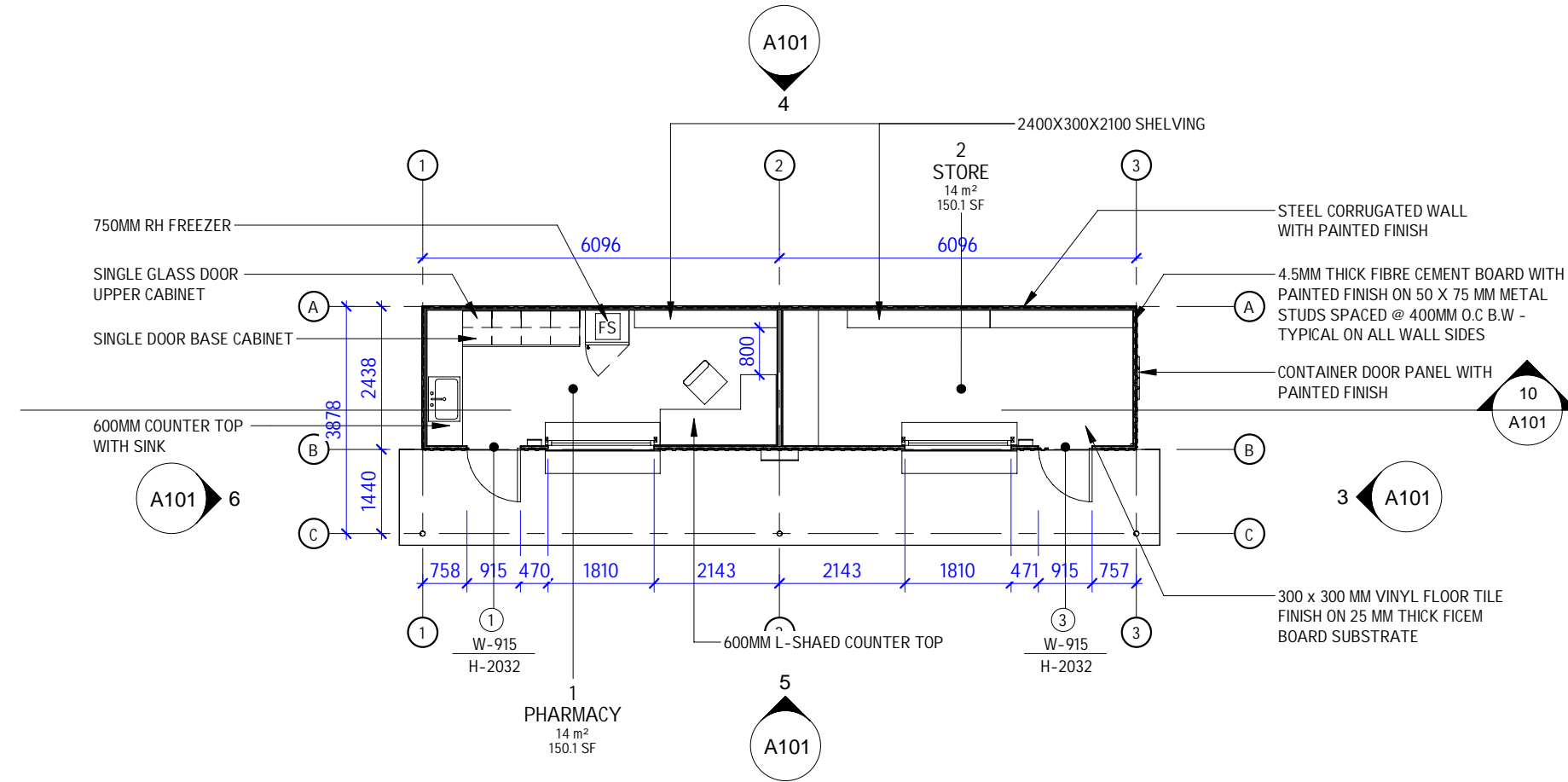

1 Level 0  
1 : 100

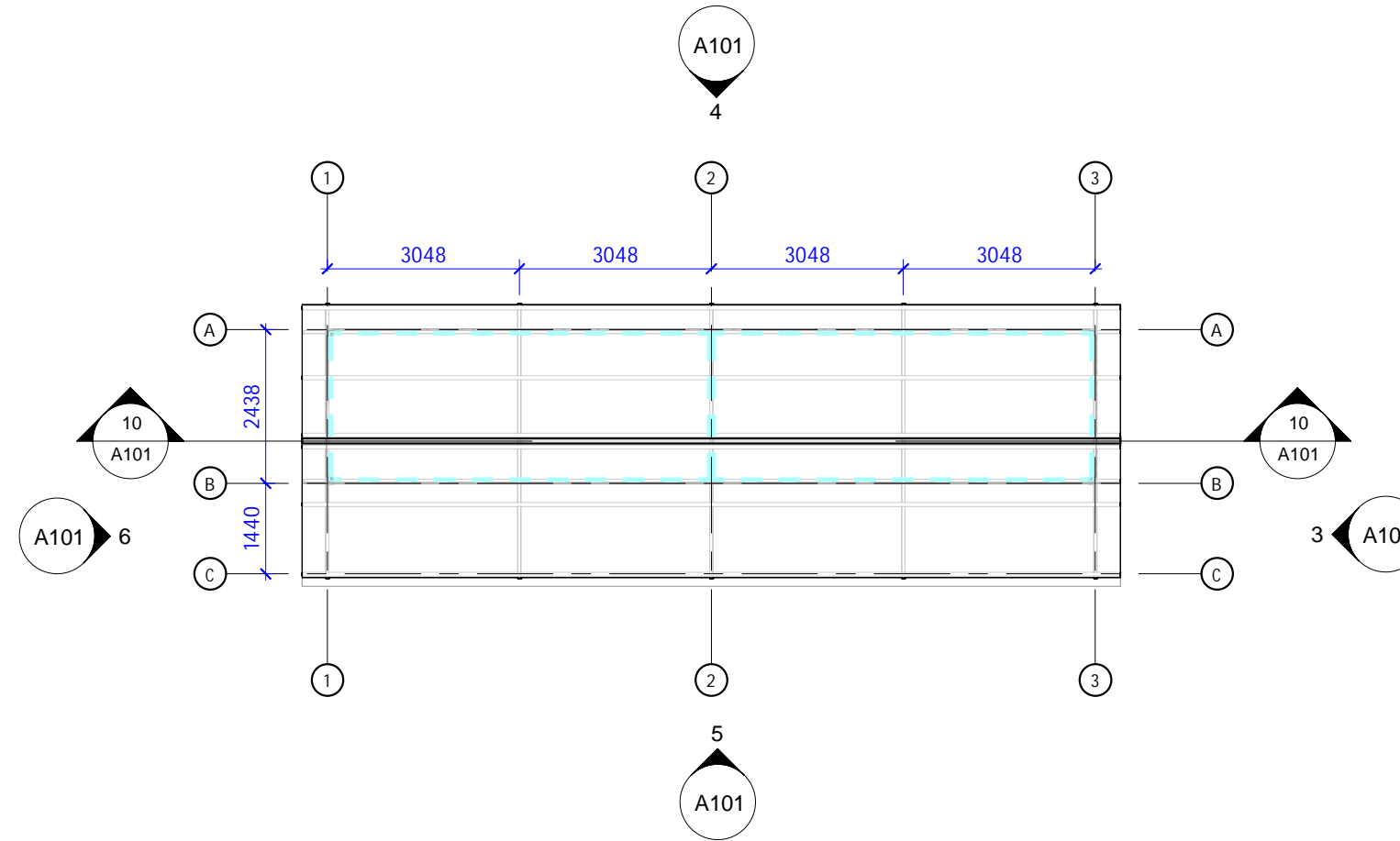

2 Level 2  
1 : 100

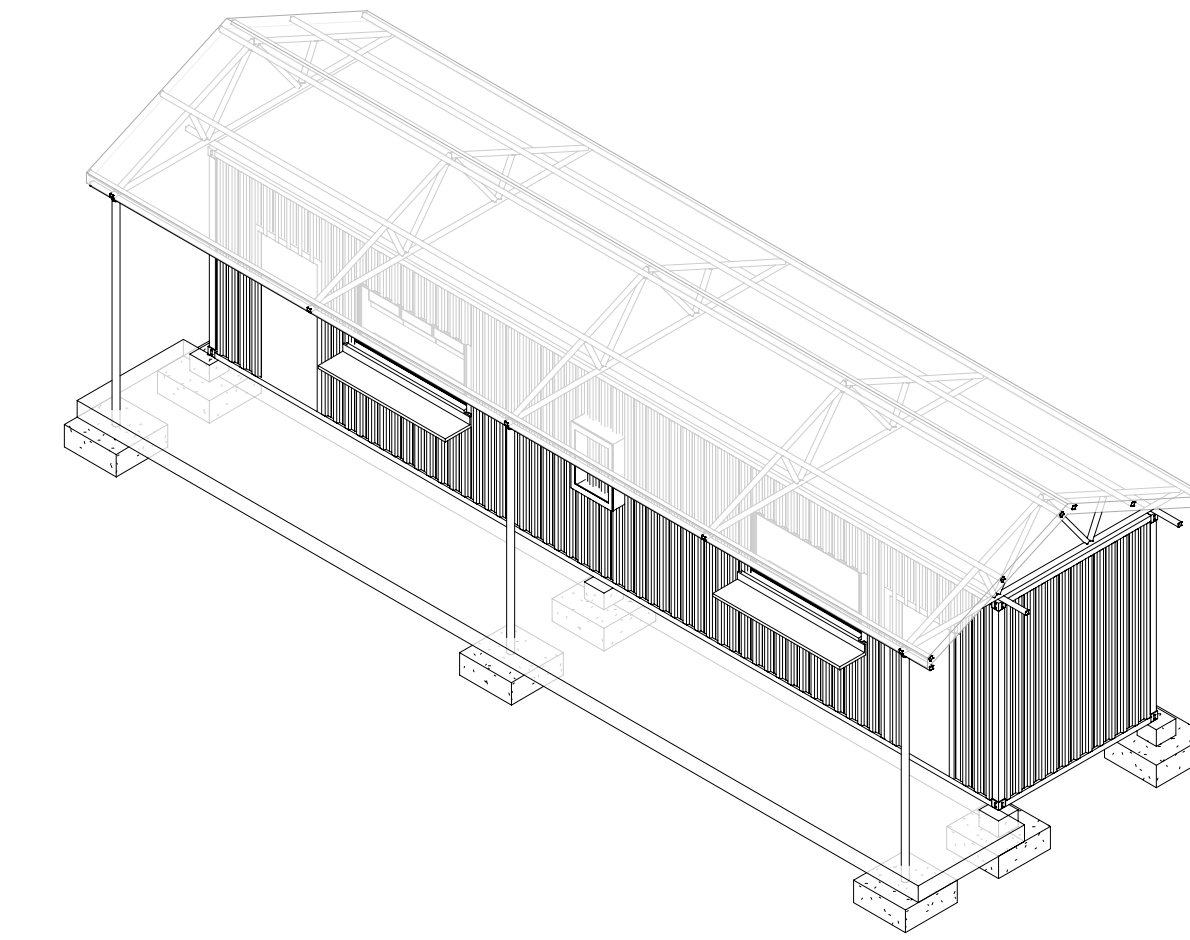

12 3D VIEW

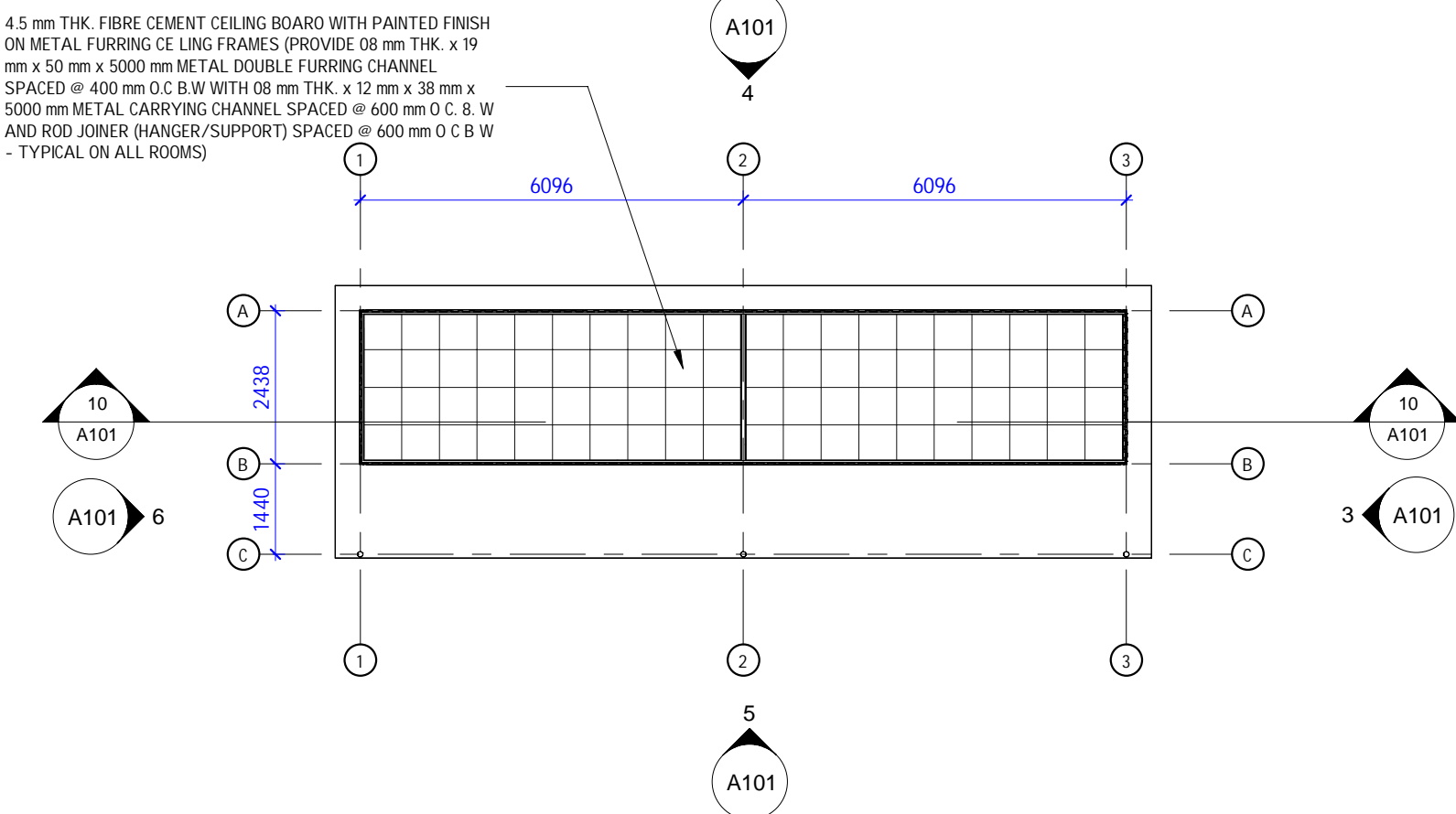

7 Level 0  
1 : 100

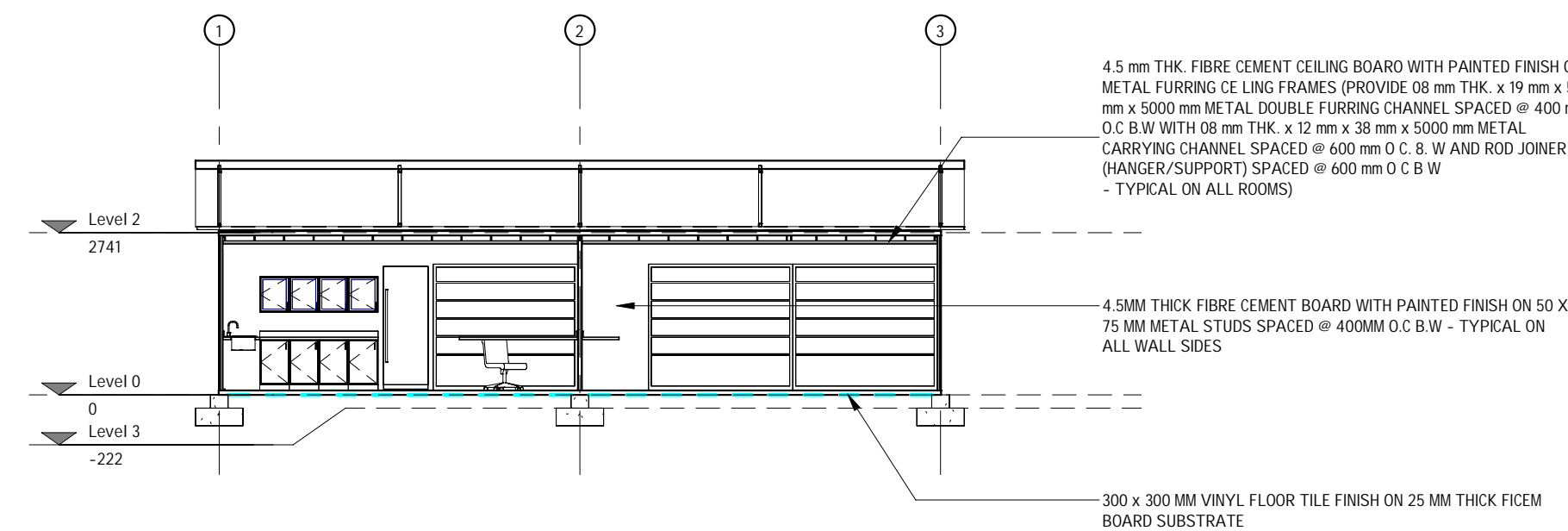

10 LONGITUDINAL SECTION  
1 : 100

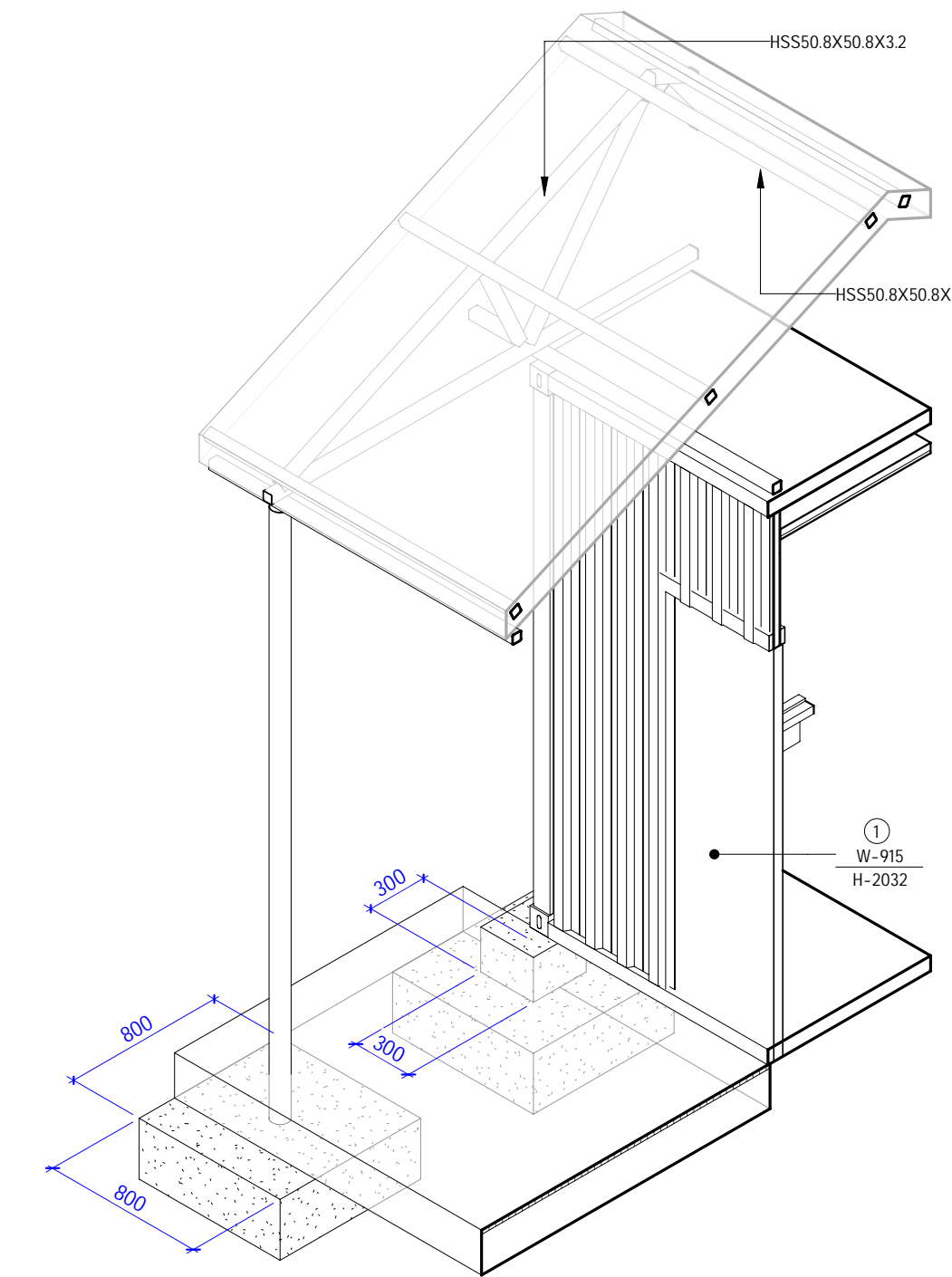

13 3D S1 CALLOUT C1

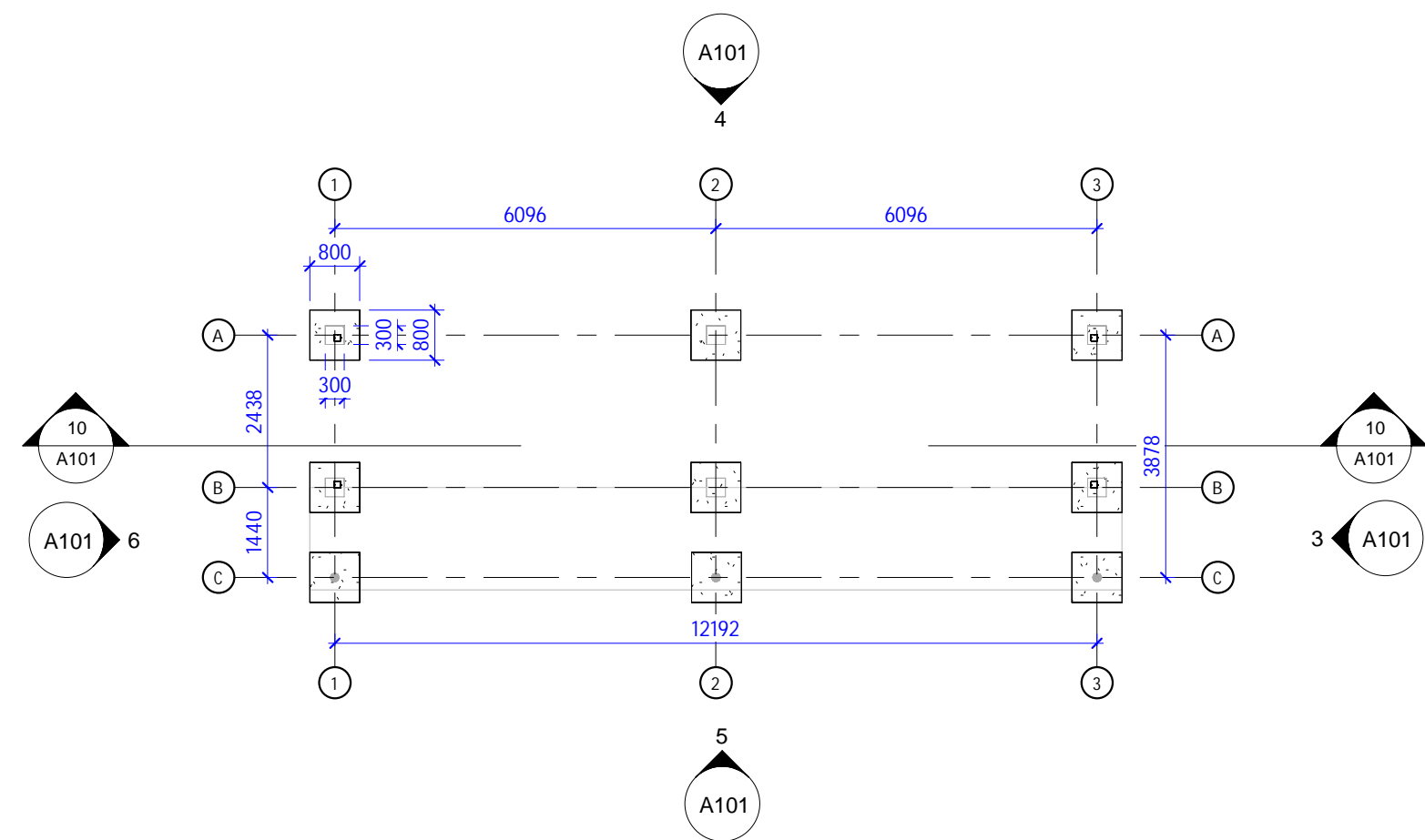

9 Level 3  
1 : 100

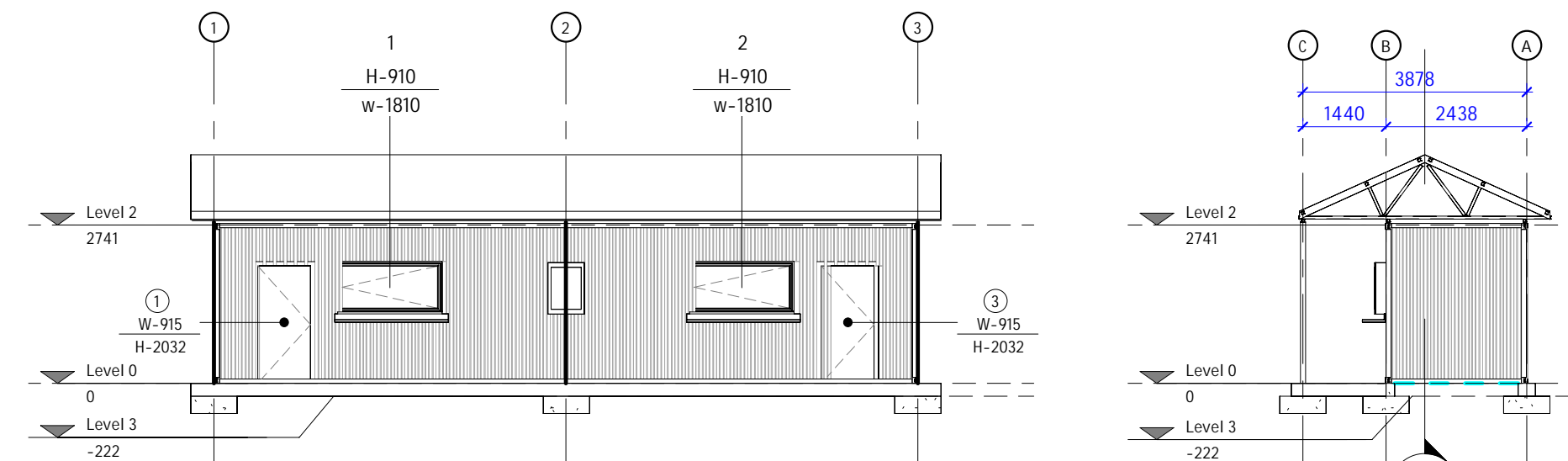

5 SOUTH ELEVATION  
1 : 100

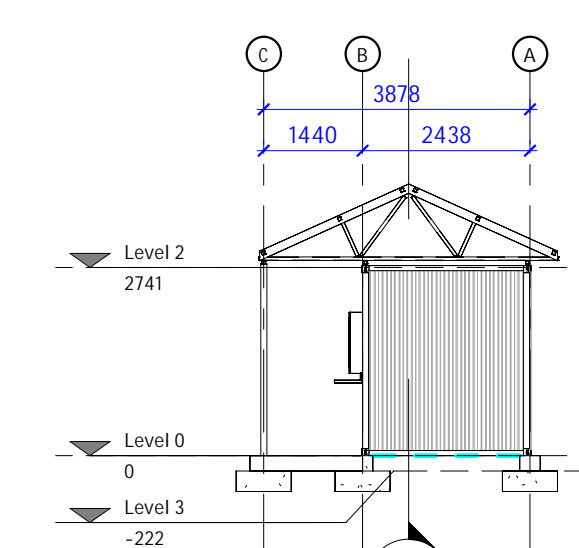

3 EAST ELEVATION  
1 : 100

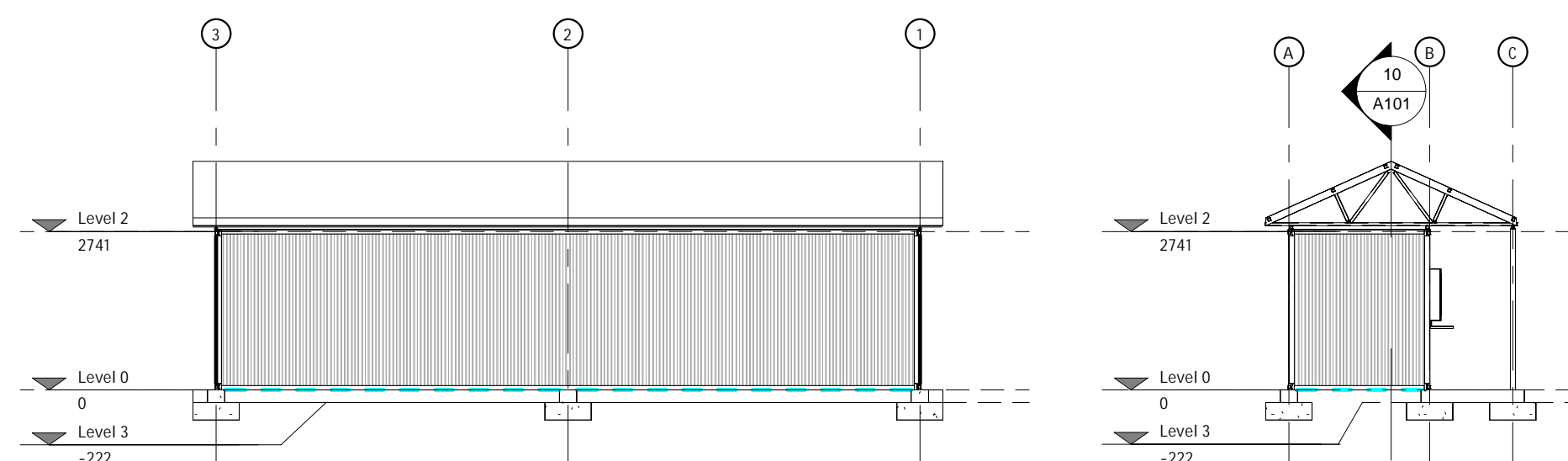

4 NORTH ELEVATION  
1 : 100

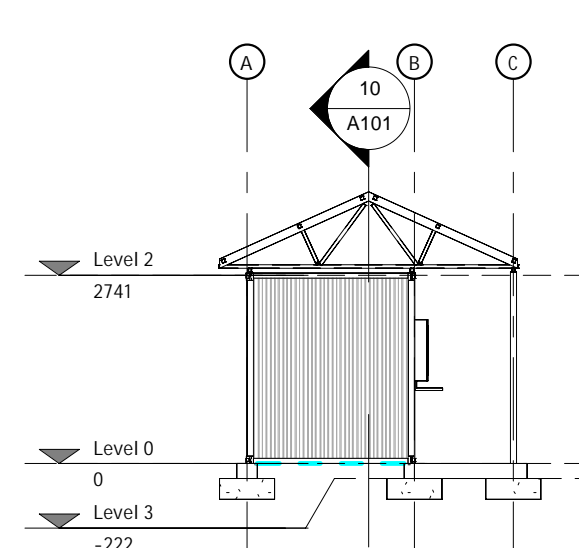

6 WEST ELEVATION  
1 : 100

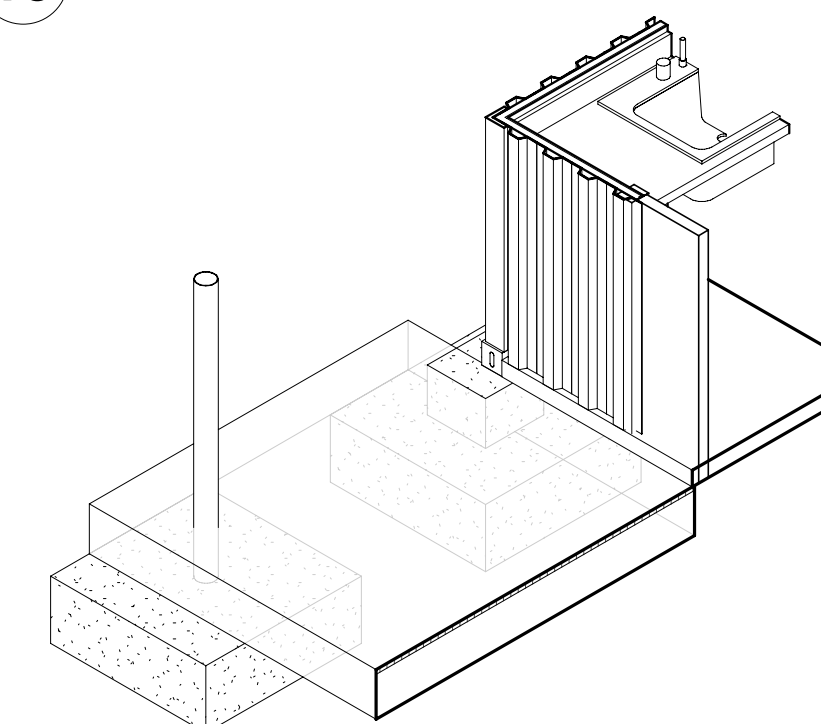

14 3D C1 CALLOUT C2

Notes:

- Sample Notes
- CONTAINER VAN:
    - USE 40FT HIGH-CUBE CONTAINER VAN (40FT x 8FT x 9FT)
    - USE SPRAY INSULATING FOAM/SEALANT FOR GAPS
    - USE TROWEL-ON WATERPROOFING MEMBRANE BETWEEN BACKERBOARD AND PVC TILE
    - USE SCOTCH WELD ACRYLIC ADHESIVE FOR PVC TILES
    - PROVIDE TWO (2) 25 mm THK. FIBER CEMENT BOARD UNDER D-2 FOR
  - WALL INSULATION:
    - PROVIDE 8 mm THK. WALL INSULATION W1 2 - LAYERS POLYETHYLENE BUBBLED FILM BONDED / LAMINATED BETWEEN THE ALUMINUM FOIL RADIANT BARRIER - REFER TO MANUFACTURER'S SPECIFICATIONS
  - FOR ROOF INSULATION:
    - PROVIDE 8 mm THK. ROOF INSULATION W1 2 - LAYERS POLYETHYLENE BUBBLED FILM BONDED / LAMINATED BETWEEN THE ALUMINUM FOIL RADIANT BARRIER - REFER TO MANUFACTURER'S SPECIFICATIONS
  - FOR FLOOR INSULATION:
    - PROVIDE 8mm THK. FLOOR INSULATION W1 2 - LAYERS POLYETHYLENE BUBBLED FILM BONDED / LAMINATED BETWEEN THE ALUMINUM FOIL RADIANT BARRIER - REFER TO MANUFACTURER'S SPECIFICATIONS

REV	DESCRIPTION	BY	DATE
	NEW CONSTRUCTION		
STATUS:			
UPPERHILL ROAD   OFF HAILE SELASSIE AVENUE P.O BOX 54238-00200 NAIROBI, KENYA EMAIL: info@fluidsparkin.com CONTACT +254(715)26-4234   +254(704)13-2074			
CLIENT:			
Africa Inland Church-HM NAIROBI. P.O. BOX, 40431-00100 NBI.			
ARCHITECT:			
SITE:			
KAKUMA			
TITLE:			
CONTAINER ARCHITECTURAL			
SCALE AT A1:	DATE:	DRAWN:	CHECKED:
As indicated	04/12/2024	SHEM	O&B
PROJECT NO:	DRAWING NO:	REVISION:	
PJ1045	A101		

# Container Base Drawing

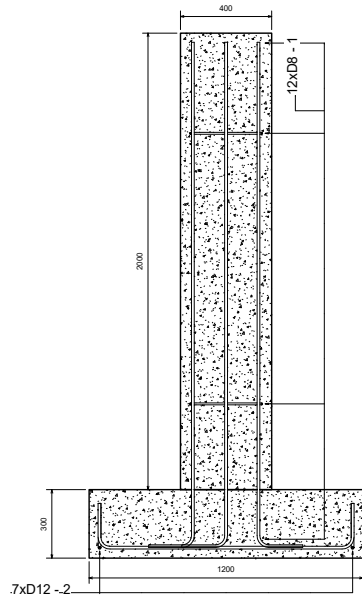

① Section 1  
1:10

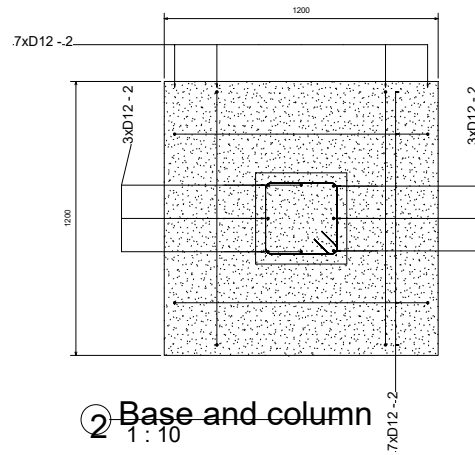

② Base and column  
1:10

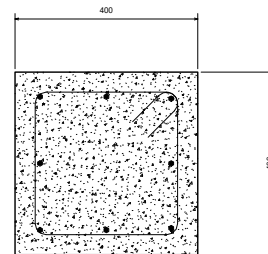

④ Pad column Details  
1:5

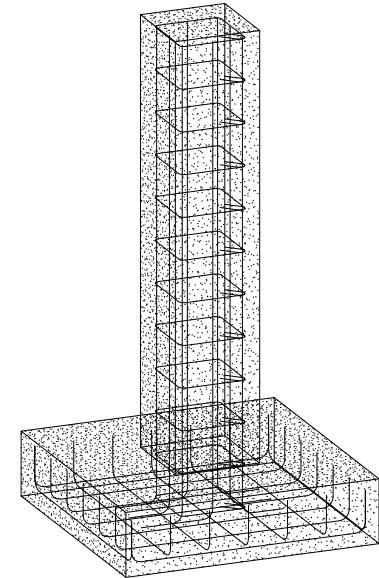

③ {3D}

CLIENT:  
AICHM



Project:  
TYPICAL CONTAINER  
FOUNDATION BASES

Title: CONSTRUCTION  
DRAWINGS

# Waiting Shed Drawing

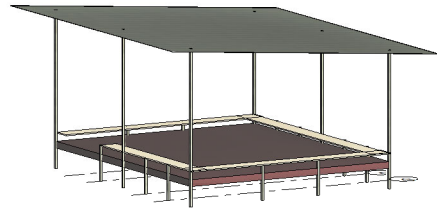

1 {3D}

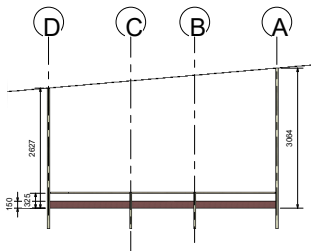

4 North  
1:50

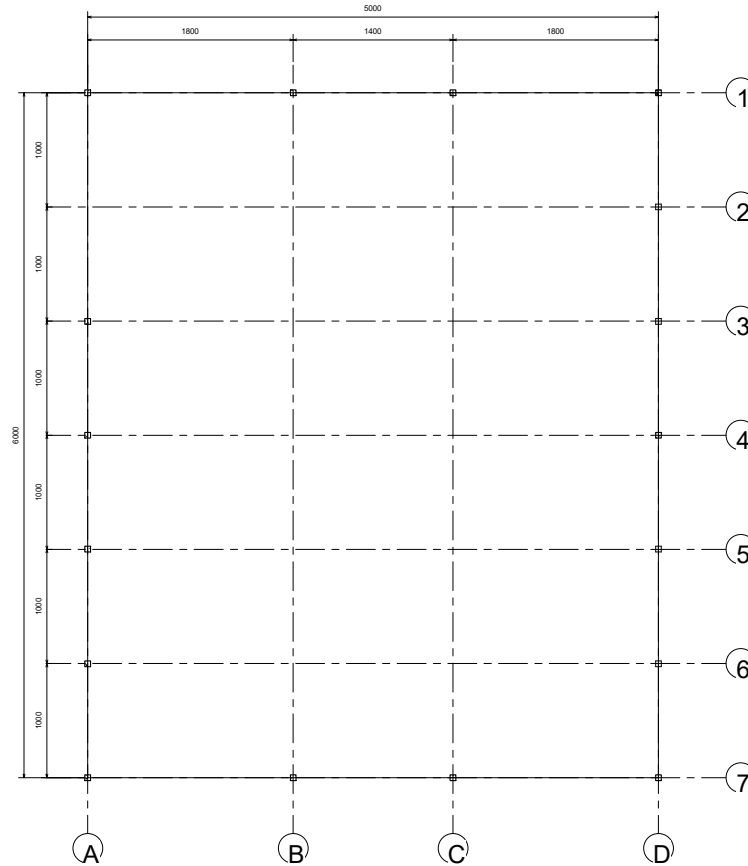

2 Ground  
1:20

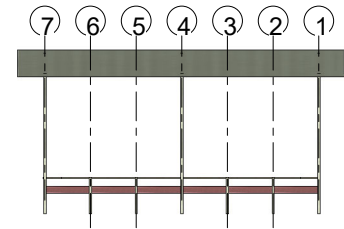

3 East  
1:50

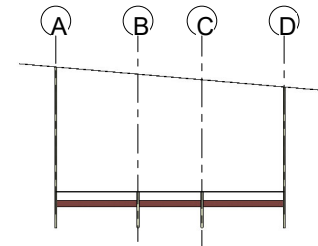

5 South  
1:50

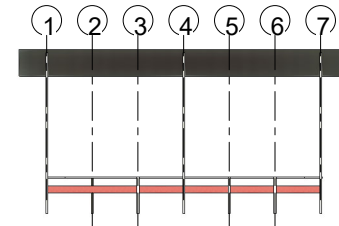

6 West  
1:50

CLIENT:  
AICHM



Project:  
CONSTRUCTION OF WAITING  
SHADE

Title: CONSTRUCTION  
DRAWINGS